



# Motor Installation Requirements Based on 2020 NEC Part 1

Presented by:

Electrical Association

Of Minnesota



# Part 1

## 2-hour Code credit

---

Motors and Associated Electrical Code



# DISCLAIMER

“Through the presentation of this course and/or these materials no representation actual or implied is made that the trainer or MEA/ETN is setting or enforcing specific standards or is providing peer review, certification, accreditation, or product testing”.

Use of NFPA Document 70-NEC<sup>®</sup>: **Presentation material is adapted from the 2020 NEC<sup>®</sup> NFPA 70. Actual code articles in their entirety are required to maintain compliance.**

**This course offering is recognized by the Minnesota Department of Labor and Industry for satisfying 2 hours of electrical code credit for continuing education.**

Meets IACET requirements for CEU's

Copyright 2019 Electrical Association



# Learning outcomes

Upon completion of the class, the participant should be able to do the following, within the parameters of the electrical industry

---

- Identify the components of a typical motor installation
- Use the NEC to locate the correct article numbers that pertain to motor installation
- Describe the effects of voltage variations on motor performance
- Explain the application of the motor nameplate data
- Describe the variables regarding motor insulation class
- Calculate the locked rotor motor current based on code letter
- Convert HP to KW for use in interpolation of motor current for IEC motors

# Learning Outcomes



- Determine feeder size for multiple motor installations
- Calculate correct branch circuit current and conductor size for individual motors
- Determine maximum short circuit and ground fault protection for motor circuits
- Design a code compliant basic motor control circuit
- Select a suitable controller
- Determine the size for correct motor overload protection
- Apply the proper setting for electronic overload protection
- Use the NEC to determine the correct number of overload devices
- Size Motor Branch Circuit -Short circuit and ground fault protection
- Determine Feeder- Short circuit and ground fault protection

# Introduction & 430.1

General, 430.1 through 430.18  
 Motor Circuit Conductors, 430.21 through 430.29  
 Motor and Branch-Circuit Overload Protection, 430.31 through 430.44  
 Motor Branch-Circuit Short-Circuit and Ground-Fault Protection, 430.51 through 430.58  
 Motor Feeder Short-Circuit and Ground-Fault Protection, 430.61 through 430.63  
 Motor Control Circuits, 430.71 through 430.75  
 Motor Controllers, 430.81 through 430.90  
 Motor Control Centers, 430.92 through 430.98  
 Disconnecting Means, 430.101 through 430.113  
 Adjustable-Speed Drive Systems, 430.120 through 430.131  
 Over 1000 Volts, Nominal, 430.221 through 430.227  
 Protection of Live Parts—All Voltages, 430.231 through 430.233  
 Grounding—All Voltages, 430.241 through 430.245  
 Tables, Tables 430.247 through 430.251(B)

Part I  
 Part II  
 Part III  
 Part IV  
 Part V  
 Part VI  
 Part VII  
 Part VIII  
 Part IX  
 Part X  
 Part XI  
 Part XII  
 Part XIII  
 Part XIV

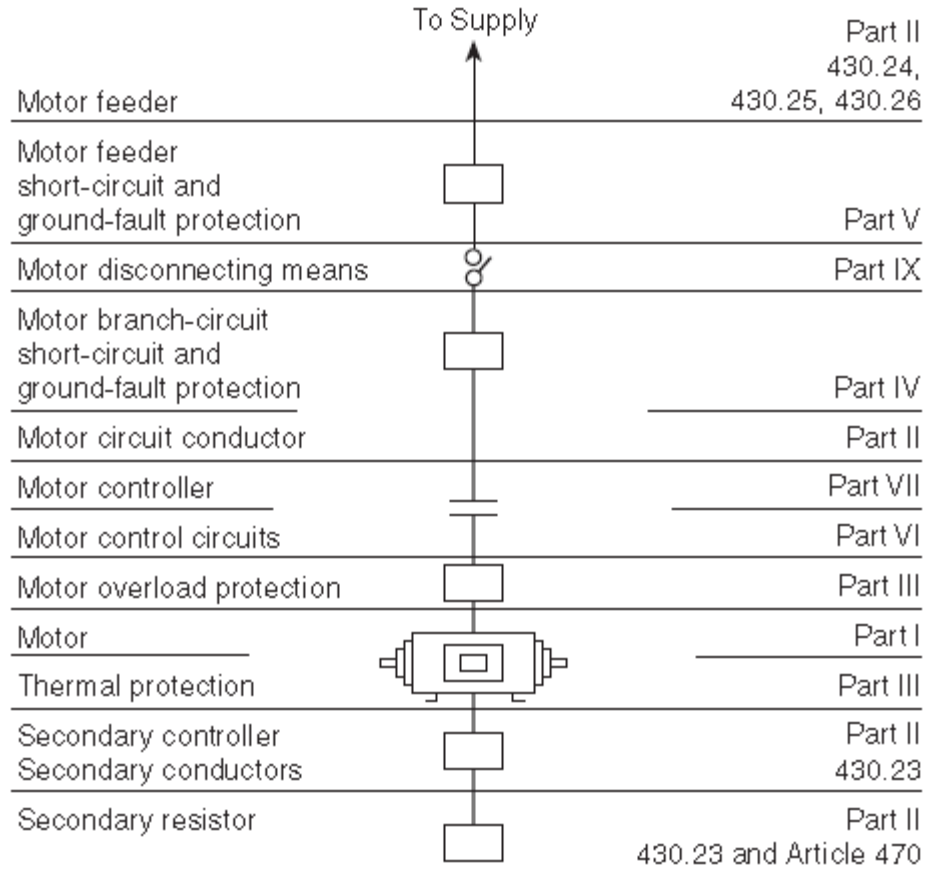

# Motor Nameplate



---

## National Electrical Code

### NFPA 70

Usual motor application nameplate requirements are in 430.7



# Motor Information Shall Contain:

- 
- Name of Manufacturer

# Effects of motor supply voltage variations.



## Voltage – rated/tested value

The circuit voltage for induction motors should generally be within **±10 percent** of the motor nameplate rating.

# Effects of motor supply voltage variations



---

Voltage differences between phase conductors of three-phase motor circuits **cause unequal phase currents which can exceed the nameplate rating**. Under such conditions, **torque and full-load speed will be slightly decreased and operating temperature will increase**. The percentage of full-load current imbalance will be 6 to 10 times the percentage of the voltage imbalance. *(For example, a 1 percent difference in voltage between phase conductors of a 480-volt circuit (4.8 volts) can produce a 6 to 10 percent difference in phase currents.)* .

Three percent voltage imbalance decreases the horsepower a motor can deliver without overheating to about 90 percent of its nameplate rating.

# Effects of motor supply voltage variations



Overvoltage and undervoltage have the effects of:

Characteristic	Voltage	
	110%	90%
Starting torque	Increase 21%	Decrease 19%
Full-load torque	Increase 21%	Decrease 19%
Full-load speed	Increase 1%	Decrease 1.5%
Full-load efficiency	Increase 0.05-0.1%	Decrease 0.2%
F.L. power factor	Decrease 0.3%	Increase 0.1%
Starting current	Increase 10-12%	Decrease 10-12%
Full-load current	Decrease 7%	Increase 11%
Temperature rise	Decrease 3-4°C	Increase 6 -7°C
Maximum overload	Increase 21%	Decrease 19%

# Motor Information Shall Contain



- 
- Amperes – operating at rated voltage and HP at full mechanical load (*not necessarily code book value*) *Full load for each speed- except for shaded pole and Perm split cap motors*

# Motor Information Shall Contain



---

Rated frequency - designed to operate at rated values HP and speeds at rated frequency and number of phases

# Motor Information Shall Contain:

---



- Horsepower – energy output at the motor shaft at 100% of mechanical load



# Motor Information Shall Contain

---

- RPM – at rated voltage, HP, and at full load

# Motor Information Shall Contain



- 
- Insulation System Class and ambient temperature, or rated temperature rise



# Insulation Class Letter

---

CLASS A - 105°C

CLASS B - 130°C

CLASS F - 155°C

CLASS H - 180°C many modern motors are upgrading to this higher temp insulation

Life expectancy of motor insulation at 20,000 hours

# Insulation Class

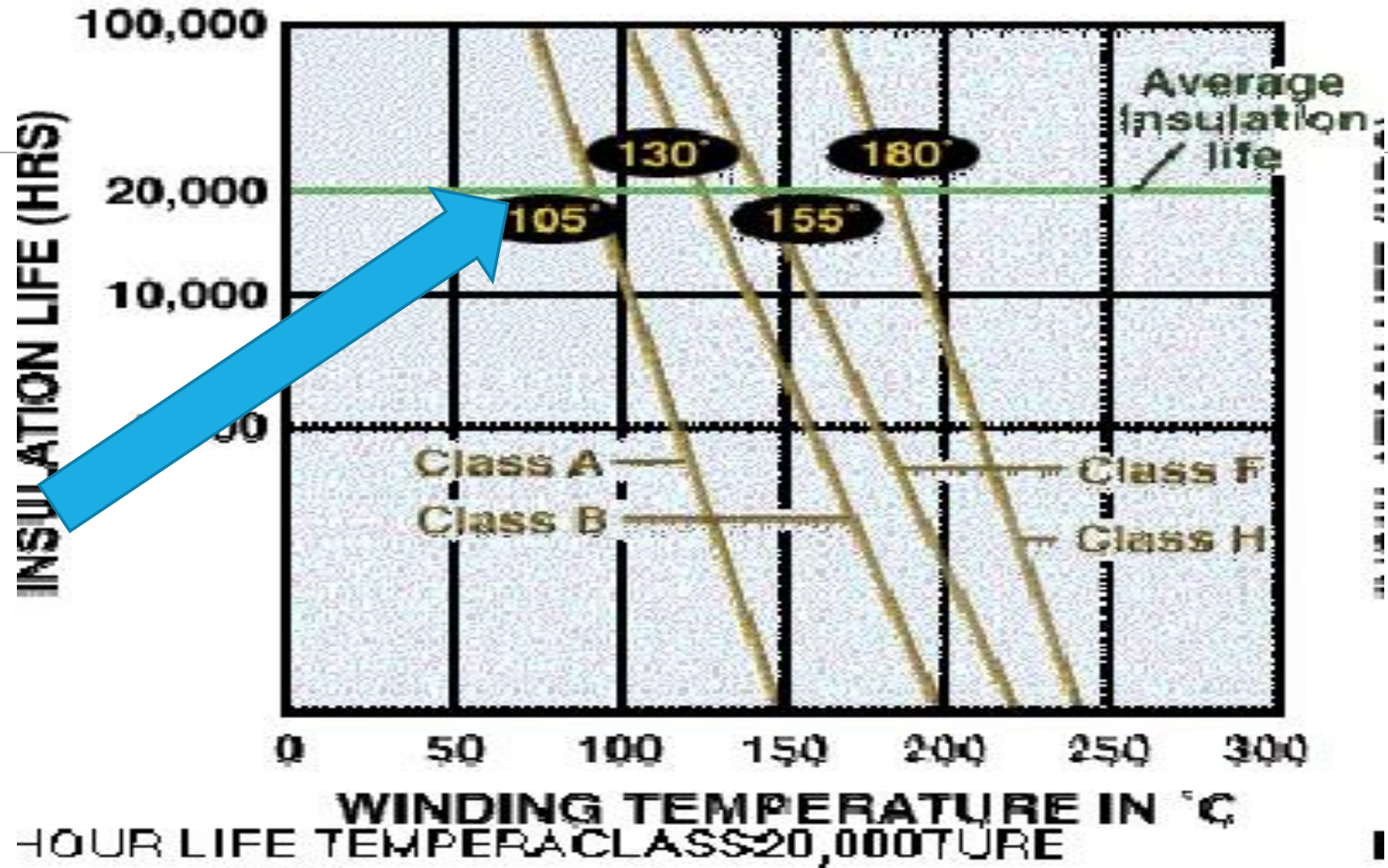

Winding Temperature (°C)	Insulation Class
105°C	A
130°C	B
155°C	F
180°C	H

# Temp Rise vs. Safe Insulation Temperature



Temperature Tolerance Class	Maximum Operation Temperature Allowed		Allowable Temperature Rise at full load 1.0 service factor motor 1)	Allowable Temperature Rise 1.15 service factor motor 1)
	°C	°F	°C	°C
A	105	221	60	70
B	130	266	80	90
F	155	311	105	115
H	180	356	125	-



# Motor Information Shall Contain

---

Time rating: ratings at 5 min, 15, 30, 60, or Continuous



# Motor Information Shall Contain

---

Service Factor – a multiplier (factor) applied to the rated HP indicating the HP over the nameplate – the motor may operate for short periods

# Motor Information Shall Contain



- 
- Code letter – locked rotor kVA – starting current

## Table 430.7(B) Locked-Rotor Indicating Code Letters

Code Letter	Kilovolt-Amperes per Horsepower with Locked Rotor
• A	0–3.14
• B	3.15–3.54
• C	3.55–3.99
• D	4.0–4.49
• E	4.5–4.99
• F	5.0–5.59
• G	5.6–6.29
• H	6.3–7.09
• J	7.1–7.99
• K	8.0–8.99
• L	9.0–9.99
• M	10.0–11.19
• N	11.2–12.49
• P	12.5–13.99
• R	14.0–15.99
• S	16.0–17.99
• T	18.0–19.99
• U	20.0–22.39
• V	22.4 and up



# Motor Information Shall Contain

- **Design Letter – operating characteristics of the motor**
- See following slides



# Design “A” Motors

---

Not commonly specified but specialized motors used on injection molding applications have characteristics similar to Design A.

The most important characteristic of **Design A is the high pullout torque.**

# Design “B” Motor



---

The standard industrial duty motor which has reasonable starting torque with moderate starting current and good overall performance for most industrial applications.



# Design “C” Motor

---

Is used for hard to start loads and is specifically designed to have high starting torque.

# Design “D” Motor



---

Are suited for low speed, punch press applications and hoist and elevator applications. The efficiency of Design D motors at full load is rather poor and are normally used on applications where the torque characteristics are of primary importance.

# Motor Design Speed / Torque Curves

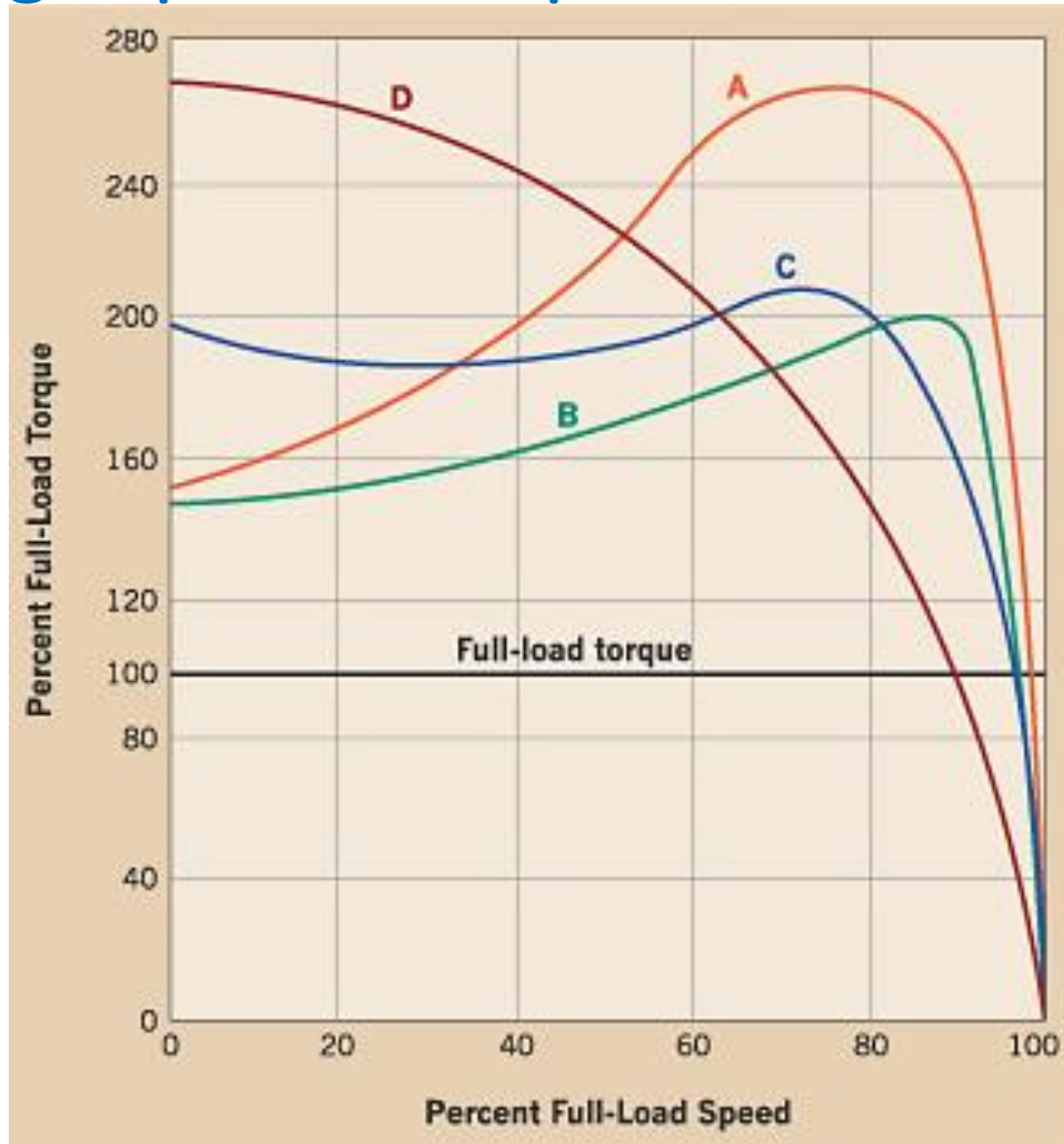



---

# General Single Motor Installation

# Motor Nameplate Information for example calculations



---

**30HP, 460V, 38A, 3 $\phi$ , S.F. 1.15,  
40°C AMB., Code G, Design B, Cont. Duty, 1725 RPM, 60Hz, Ins. Class B.**

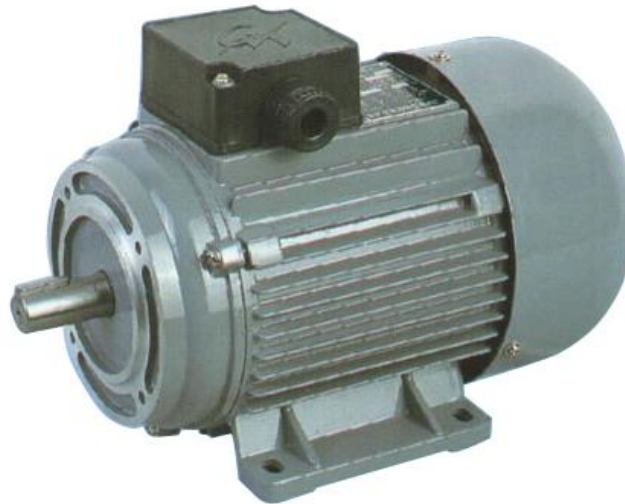



# Parameters for example motor :

---

Continuous-Duty Motors

75°C Copper Conductors

Normal Starting and Load Conditions

RPM ratings at or above 1150 (1200 Synchronous)

Service Factor 1.0 or 1.15

# Locked-Rotor Current



---

The current, in amperes, a motor draws from the source when energized at its rated voltage, but the rotor is not turning.

A code letter indicating the kVA per horsepower is found in NEC 430.7(B)

$$I_{LRC} = \frac{kVA \text{ per HP} \times HP}{E \times 1.732}$$

# Table 430.7(B) Locked-Rotor Indicating Code Letters



Code Letter	Kilovolt-Amperes per Horsepower with Locked Rotor
A.....	0 – 3.14
B.....	3.15 – 3.54
C.....	3.55–3.99
D.....	4.0 – 4.49
E.....	4.5 – 4.99
F.....	5.0 – 5.59
<b>G.....</b>	<b>5.6 – 6.29</b>
H.....	6.3 – 7.09
J.....	7.1 – 7.99
K.....	8.0 – 8.99
L.....	9.0 – 9.99
M.....	10.0 – 11.19
N.....	11.2 – 12.49
P.....	12.5 – 13.99



# Code Letter – Table 430.7(B)

---

Locked Rotor kVA per Horsepower – same as starting current

Code G 5.60 – 6.29,

$$6.29 \times 30 \text{ HP} = \underline{119.7 \text{ kVA}} = 236.8 \text{ amps}$$
$$(460 \times 1.732)$$

Maximum starting current is **236.8 amps**

# Worksheet:

## Multi-motor installation using 3 phase motors

---

**Motors are: Continuous duty, Design B motors**

**75 HP**

**60 HP**

**50 HP**

**40 HP**



# Worksheet Example: Calculate LRC

## Motor Branch Circuit Calculations

HP	MOTOR	VOLTS	PH	Name Plate Current Rating	Code Book Current Value	Code Letter	Service Factor	Maximum Locked Rotor Current	Minimum Size THWN Conductor	Maximum Trip Setting	Maximum SC & GF Dual-Element Time-Delay Fuse	Minimum Controller Size
75	M-1	460	3	92	96	H	1.15					
60	M-2	460	3	68	77	G	1.15					
50	M-3	460	3	58	65	G	1.15					
40	M-4	460	3	46	52	H	1.00					

## Motor Feeder Calculations

Minimum Circuit Ampacity	Minimum Size THWN Conductor	Maximum SC & GF Dual Element, Time Delay Fuse



# Worksheet Answers: LRC

## Motor Branch Circuit Calculations

HP	MOTOR	VOLTS	PH	Name Plate Current Rating	Code Book Current Value	Code Letter	Service Factor	Maximum Locked Rotor Current	Minimum Size THWN Conductor	Maximum Trip Setting	Maximum SC & GF Dual-Element Time-Delay Fuse	Minimum Controller Size
75	M-1	460	3	92	96	H	1.15	667				
60	M-2	460	3	68	77	G	1.15	474				
50	M-3	460	3	58	65	G	1.15	395				
40	M-4	460	3	46	52	H	1.00	356				

## Motor Feeder Calculations

Minimum Circuit Ampacity	Minimum Size THWN Conductor	Maximum SC & GF Dual Element, Time Delay Fuse

# 430.6 – Determine the values to be used to size the motor Equipment



- 
- (1) The values given in Tables 430.247, 248, 249, and 250 shall be used to determine the ampacity of:
- conductors or
  - ampere ratings of switches,
  - branch-circuit short-circuit and ground-fault protection,
  - **instead of the actual current marked on the motor nameplate.**



# 430.6 – Determine the values to be used to size the motor hardware

Where a motor is marked in amperes, not horsepower, the HP rating shall be assumed to be corresponding to the value in Tables 430.247, .248, .249, and .250, **interpolated if necessary**.

Motors built for low speed or high torque, or multispeed motors - having higher full-load currents than the table, the nameplate current ratings shall be used.

See exceptions 1-3



**Table A: Dimensions and Frame Comparisons, IEC and NEMA**

IEC NEMA	IEC and NEMA dimensions in mm							KW and HP Ratings 3 Phase TEFC Motors		
	(H) D	(A) E	(B) F	(K) H	(D) U	(C) BA	(E) N-W	2 Pole	4 Pole	6 Pole
56 NA	56 ---	45 ---	35.5 ---	5.8 ---	9 ---	36 ---	20 ---	---	---	---
63 42	63 66.7	50 44.5	40 21.4	7 7.1	11 9.5	40 52.4	23 28.6	.25 KW 1/3 HP	.18KW 1/4 HP	---
71 48	71 76.2	56 54	45 34.9	7 8.7	14 12.7	45 63.5	30 38.1	0.55 3/4	0.37 1/2	---
80 56	80 88.9	62.5 61.9	50 38.1	10 8.7	19 15.9	50 69.9	40 47.6	1.1 1-1/2	0.75 1	0.55 3/4
90S 143T	90 88.9	70 69.8	50 50.8	10 8.7	24 22.2	56 57.2	50 57.2	1.5 2	1.1 1-1/2	0.75 1
90L 145T	90 88.9	70 69.8	62.5 63.5	10 8.7	24 22.2	56 57.2	50 57.2	2.2 3	1.5 2	1.1 1-1/2
100L NA	100 ---	80 ---	70 ---	12 ---	28 ---	63 ---	60 ---	3 4	2.2 3	1.5 2
112S 182T	112 114.3	95 95.2	57 57.2	12 10.7	28 28	70 70	60 69.9	3.7 5	2.2 3	1.5 2
112M 184T	112 114.3	95 95.2	70 68.2	12 10.7	28 28	70 70	60 69.9	3.7 5	4 5.4	2.2 ---
132S 213T	132 133.4	108 108	70 69.8	12 10.7	38 34.9	89 89	80 85.7	7.5 10	5.5 7-1/2	3 ---
132M 215T	132 133.4	108 108	89 88.8	12 10.7	38 34.9	89 89	80 85.7	---	7.5 10	5.5 7-1/2
160M* 254T	160 158.8	127 127	105 104.8	15 13.5	42 41.3	108 108	110 101.6	15 20	11 15	7.5 10
160L* 256T	160 158.8	127 127	127 127	15 13.5	42 41.3	108 108	110 101.6	18.5 25	15 20	11 15

# Motor nameplate for kW rating





# 430.6 – Determine the values to be used to size the motor hardware

## (2) Nameplate Values.

Separate **motor overload protection shall be based on the motor nameplate current rating.**

<b>SIEMENS</b>									
PE•21 PLUS™					PREMIUM EFFICIENCY				
ORD.NO.	1LA02864SE41				E. NO.				
TYPE	RGZESD				FRAME	286T			
H. P.	30.00				SERVICE FACTOR	1.15		3 PH	
AMPS	34.9				VOLTS	460			
R.P.M.	1765				HERTZ	60			
DUTY	CONT 40°C AMB.					DATE CODE			
CLASS INSUL	F	NEMA DESIGN	B	K.V.A. CODE	G	NEMA. NOM. EFF.	93.6		
SH. END BRG.	50BC03JPP3				OPP. END BRG.	50BC03JPP3			
<b>MILL AND CHEMICAL DUTY QUALITY INDUCTION MOTOR</b>									
Siemens Energy & Automation, Inc. Little Rock, AR							MADE IN U.S.A.		



# 430.6 – *Table Value for sample motor*

---

## Table 430.250

30 hp, 460 V motor - 3Ø:

**40 amps**

**2017 NEC pg. 322**

# Minimum Circuit Ampacity

A calculation necessary to select a conductor size by first applying the appropriate National Electrical Code requirements to determine the ampere rating of the expected load.

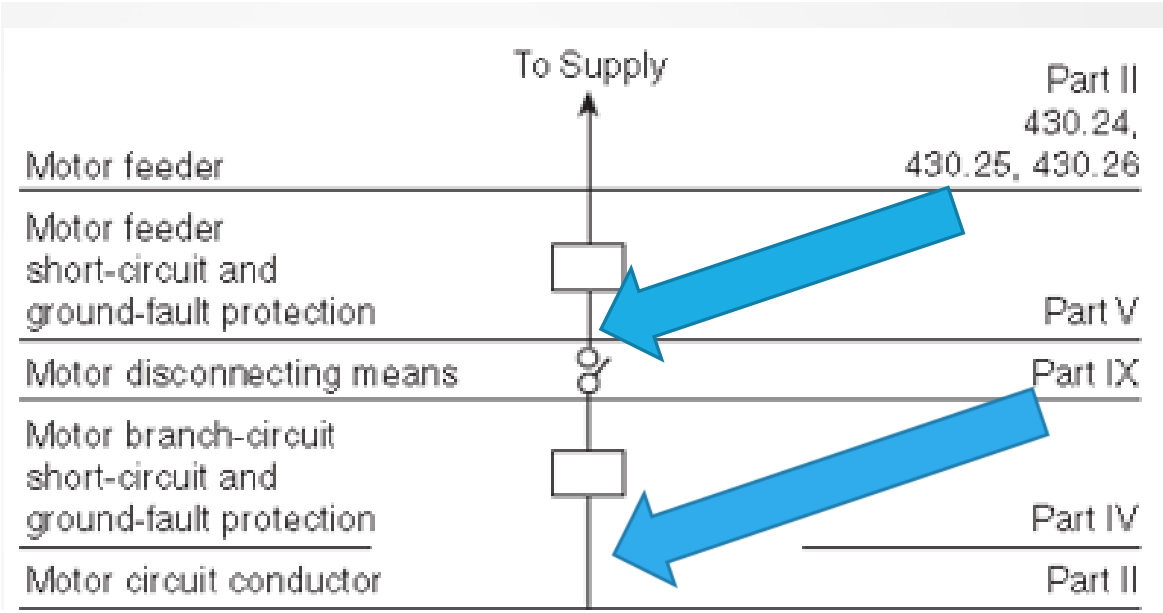

# Part II – 430.21/22 – Size the conductor



---

.22 (A) General. Conductors that supply a single motor in a continuous duty application shall have an ampacity of not less than **125 percent** of the motor's full-load current rating as determined by 430.6(A)(1) or (A) –(G)

30 hp, 480V, 38A, 3Ø, S.F. 1.15, 40°C  
AMB., Code C, Design B, cont. duty  
1725RPM, 60Hz, Ins. Class B.

Sample motor:

$$40 \times 1.25 = 50 \text{ amps}$$

8 AWG @ 75° C

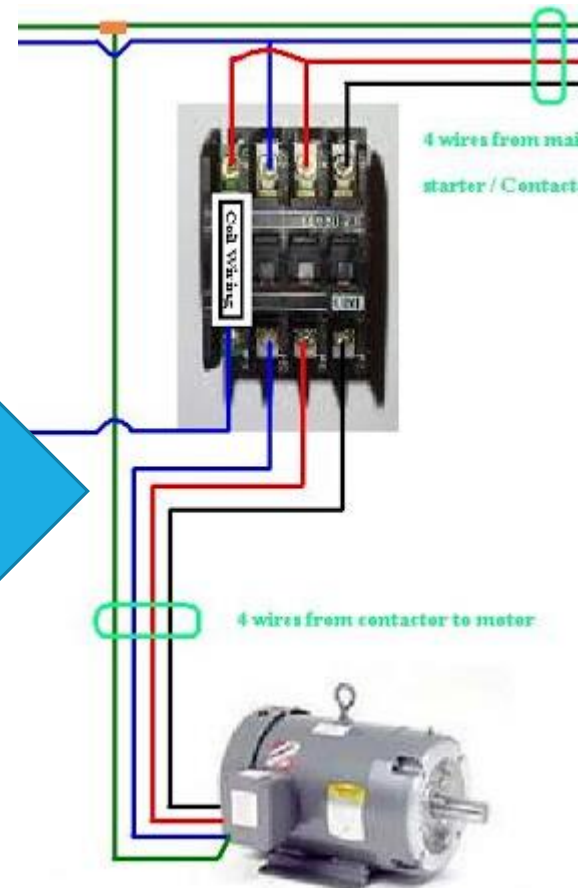

# Worksheet Example: Size wire for branch circuit



## Motor Branch Circuit Calculations

HP	MOTOR	VOLTS	PH	Name Plate Current Rating	Code Book Current Value	Code Letter	Service Factor	Maximum Locked Rotor Current	Minimum Size THWN Conductor	Maximum Trip Setting	Maximum SC & GF Dual-Element Time-Delay Fuse	Minimum Controller Size
75	M-1	460	3	92	96	H	1.15	667				
60	M-2	460	3	68	77	G	1.15	474				
50	M-3	460	3	58	65	G	1.15	395				
40	M-4	460	3	46	52	H	1.00	356				

## Motor Feeder Calculations

Minimum Circuit Ampacity	Minimum Size THWN Conductor	Maximum SC & GF Dual Element, Time Delay Fuse

# Worksheet Answers



## Motor Branch Circuit Calculations

HP	MOTOR	VOLTS	PH	Name Plate Current Rating	Code Book Current Value	Code Letter	Service Factor	Maximum Locked Rotor Current	Minimum Size THWN Conductor	Maximum Trip Setting	Maximum SC & GF Dual-Element Time-Delay Fuse	Minimum Controller Size
75	M-1	460	3	92	96	H	1.15	667	1 AWG			
60	M-2	460	3	68	77	G	1.15	474	3 AWG			
50	M-3	460	3	58	65	G	1.15	395	4 AWG			
40	M-4	460	3	46	52	H	1.00	356	6 AWG			

## Motor Feeder Calculations

Minimum Circuit Ampacity	Minimum Size THWN Conductor	Maximum SC & GF Dual Element, Time Delay Fuse



---

# Motors Installed on a Feeder



# Definition: Feeder (NEC)

---

All circuit conductors between the service equipment, the source of a separately derived system, or other power supply source and the final branch-circuit overcurrent device.

# 430.24 Several Motors or a Motor(s) and Other Load(s).



---

Conductors supplying several motors, or a motor(s) and other load(s), shall have an ampacity **not less than 125 percent of the full-load current rating of the highest rated motor** plus the sum of the full-load current ratings of all the other motors in the group, as determined by 430.6(A), plus the ampacity required for the other loads.



# Worksheet Example to size feeder

## Motor Branch Circuit Calculations

HP	MOTOR	VOLTS	PH	Name Plate Current Rating	Code Book Current Value	Code Letter	Service Factor	Maximum Locked Rotor Current	Minimum Size THWN Conductor	Maximum Trip Setting	Maximum SC & GF Dual-Element Time-Delay Fuse	Minimum Controller Size
75	M-1	460	3	92	96	H	1.15	667	1 AWG			
60	M-2	460	3	68	77	G	1.15	474	3 AWG			
50	M-3	460	3	58	65	G	1.15	395	4 AWG			
40	M-4	460	3	46	52	H	1.00	356	6 AWG			

## Motor Feeder Calculations

Minimum Circuit Ampacity	Minimum Size THWN Conductor	Maximum SC & GF Dual Element, Time Delay Fuse

# Worksheet Answers: Feeder



## Motor Branch Circuit Calculations

HP	MOTOR	VOLTS	PH	Name Plate Current Rating	Code Book Current Value	Code Letter	Service Factor	Maximum Locked Rotor Current	Minimum Size THWN Conductor	Maximum Trip Setting	Maximum SC & GF Dual-Element Time-Delay Fuse	Minimum Controller Size
75	M-1	460	3	92	96	H	1.15	667	1 AWG			
60	M-2	460	3	68	77	G	1.15	474	3 AWG			
50	M-3	460	3	58	65	G	1.15	395	4 AWG			
40	M-4	460	3	46	52	H	1.00	356	6 AWG			

## Motor Feeder Calculations

Minimum Circuit Ampacity	Minimum Size THWN Conductor	Maximum SC & GF Dual Element, Time Delay Fuse
314	400 kcmil Cu	

# 430.32

---

## Sizing the Overloads (Heaters)

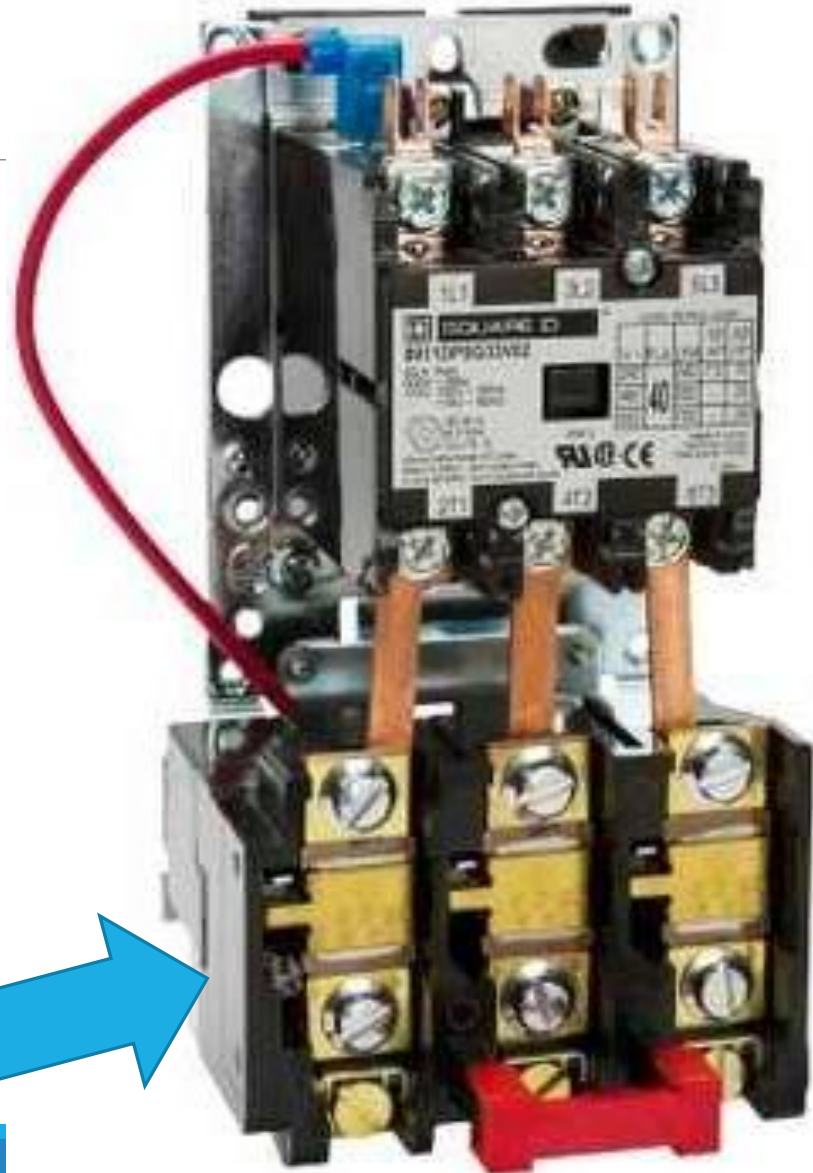



# Definition: Overload (NEC)

---

Operation of equipment in excess of normal, full-load rating, or of a conductor in excess of rated ampacity that, when it persists for a sufficient length of time, would cause damage or dangerous overheating.

A fault, such as a short circuit or ground fault, is not an overload.



# Part III – 430.31.32 – Sizing the Overloads

---

## (A) More than 1 Horsepower.

Each motor used in a continuous duty application and rated more than 1 hp shall be protected against overload by one of the means in 430.32(A)(1) - (A)(4).

# 430.32 – Sizing the Overloads

---



- (1) Separate Overload Device. A separate overload device that is responsive to motor current. This device shall be **selected to trip** or shall be rated at no more than the following percent of the motor **nameplate** full-load current rating:
- Motors with a marked service factor 1.15 or greater - **125%**
  - Motors with a marked temperature rise 40°C or less - **125%**
  - All other motors - **115%**

# 430.32 – Sizing the Overloads: Example motor

---



38A nameplate  $\times 1.25 = 47.5$  amps

the max *Trip Current Rating* of the

OL device



# Thermal overload classification

(NEMA) designates an overload relay by a class number indicating the maximum time in seconds at which it will trip when carrying a current equal to 600 percent of its current rating.

A **Class 10** overload relay **will trip in 10 seconds or less** at a current equal to **600 percent** of its rating.

A **Class 20** overload relay **will trip in 20 seconds or less** at a current equal to **600 percent** of its rating.

A **Class 30** overload relay will **trip in 30 seconds** or less at a current equal to **600 percent** of its rating.

A **class 10A** is used for IEC at 7.2 times rating trips at 2-10 seconds



# NEC overload selection

The following is for motors rated for Continuous Duty:

For motors with marked service factor of not less than 1.15, or motors with a marked temperature rise not over  $+40^{\circ}\text{C}$  ( $+104^{\circ}\text{F}$ ), apply application rules 1 through 3.

Apply application rules 2 and 3 when the temperature rise does not exceed  $+10^{\circ}\text{C}$  ( $+18^{\circ}\text{F}$ ). When the temperature difference is greater, see below.



# Practical overload selection

For motors with **Marked Service Factor of *less than 1.15***, select the “Heater Type Number” **one rating smaller than** determined by the rules in paragraphs 1, 2 and 3.



# Practical overload selection

1. **The Same Temperature at the Controller and the Motor** Select the “Heater Type Number” with the listed “Full Load Amperes” nearest the full load value shown on the motor nameplate.
2. **Higher Temperature at the Controller than at the Motor** If the full load current value shown on the motor nameplate is between the listed “Full Load Amperes”, select the “Heater Type Number” with the higher value.
3. **Lower Temperature at the Controller than at the Motor** If the full load current value shown on the motor nameplate is between the listed “Full Load Amperes”, select the “Heater Type Number” with the lower value.

## Standard **Trip-Class 20** Heater Packs

Part Number

(Three heater packs) Price Max.

Amps

Motor Full Load Ampere Rating Dial Position

A B C D

**H2001B-3** <---> 32 .254 .306 .359 .411

**H2002B-3** <---> 32 .375 .452 .530 .607

**H2003B-3** <---> 32 .560 .676 .791 .907

**H2004B-3** <---> 32 .814 .983 1.15 1.32

**H2005B-3** <---> 32 1.20 1.45 1.71 1.96

**H2006B-3** <---> 32 1.79 2.16 2.53 2.90

**H2007B-3** <---> 32 2.15 2.60 3.04 3.49

**H2008B-3** <---> 32 3.23 3.90 4.56 5.23

**H2009B-3** <---> 32 4.55 5.50 6.45 7.40

**H2010B-3** <---> 32 6.75 8.17 9.58 11.0

**H2011B-3** <---> 32 9.14 10.8 12.4 14.0

**H2012B-3** <---> 32 14.0 16.9 19.9 22.8

**H2013B-3** <---> 32 18.7 22.7 26.7 30.7

**H2014B-3** <---> 32 23.5 28.5 33.5 38.5





# Practical overload selection

Heater Element Selection Procedure — When Temperature at Controller is  $\pm 10^{\circ}\text{C}$  ( $\pm 18^{\circ}\text{F}$ ) Greater than Temperature at Motor

The ambient temperature at the motor and controller is the same in most applications. Under this condition, the overload relay is designed to sense changes in ambient temperature and also protect the motor over a range of temperatures.

# Ambient Temperature Correction



Output that a motor can safely deliver varies with temperature. The motor can deliver its full rated horsepower at an ambient temperature specified by the motor manufacturers, normally  $+40^{\circ}\text{C}$  ( $+104^{\circ}\text{F}$ ).

At high temperatures (higher than  $+40^{\circ}\text{C}$ ) less than 100% of the normal rated current can be drawn from the motor without shortening the insulation life.

At lower temperatures (less than  $+40^{\circ}\text{C}$ ) more than 100% of the normal rated current could be drawn from the motor without shortening the insulation life

Thus, there is an inverse relationship between motor ambient temperature and motor output. In any motor, allowable output decreases as the ambient temperature is raised and vice versa.

# Overload selection

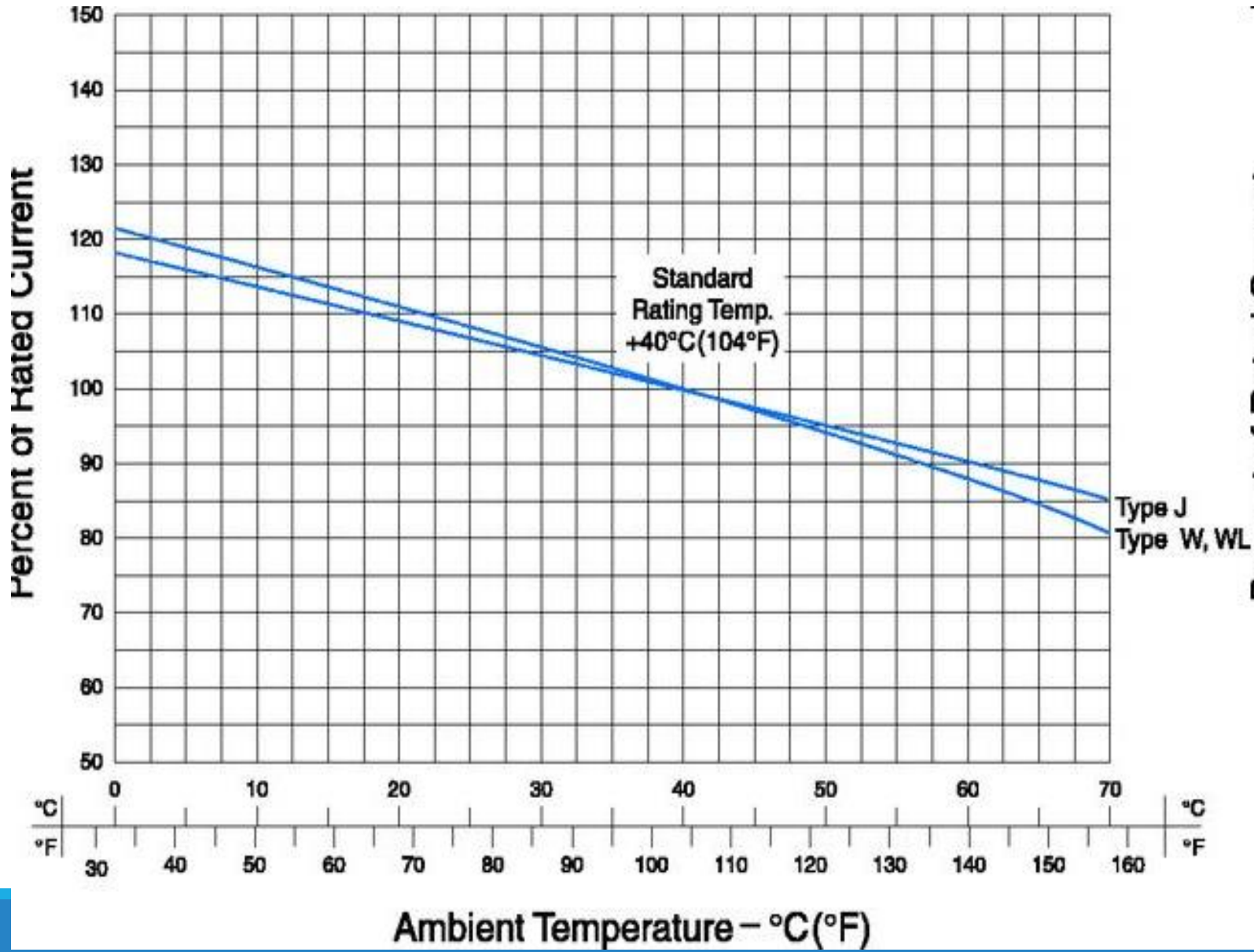



# Heater Element Tables

The heater element selection tables are designed to accommodate motor service factors of 1.15 or greater, as given in all the preceding examples. If the service factor had been less than 1.15 (for example, S.F. = 1.0) a heater element one rating smaller than selected in each example would have been the correct choice. This would provide protection at 10% lower current levels.



# Heater Table Instructions

1. Determine number of heater elements required from Table A.
2. Determine motor full load current and service factor.

NOTE: If motor amps are unknown, an approximate value may be found. These values should be used with caution and only when motor amps are not available.

3. If the motor and controller are in the same ambient temperature:
  - a. For 1.15 to 1.25 service factor motors use 100% of motor full load current for heater element selection.
  - b. For 1.0 service factor motors use 90% of motor full load current for heater element selection.
  - c. Heater elements are class 20.
4. If the motor and controller are in different ambient temperatures multiply motor full load current by the multiplier. Use the resultant full load current for heater element selection.
5. Select proper heater element from table below.
6. All tables are based on the operation of the motor and controller in the same ambient temperature, 40°C (104°F) or less. Always be certain the correct heater element is installed in the starter before operating the motor.

# Electronic overload selection

Electronic Overload Relay.

Selectable trip class.

Selectable reset mode.

Overload setting is 120% of motor current.

For 1.15 Service Factor or greater, set at motor nameplate current. SF less than 1.15, set at 90% of motor current.

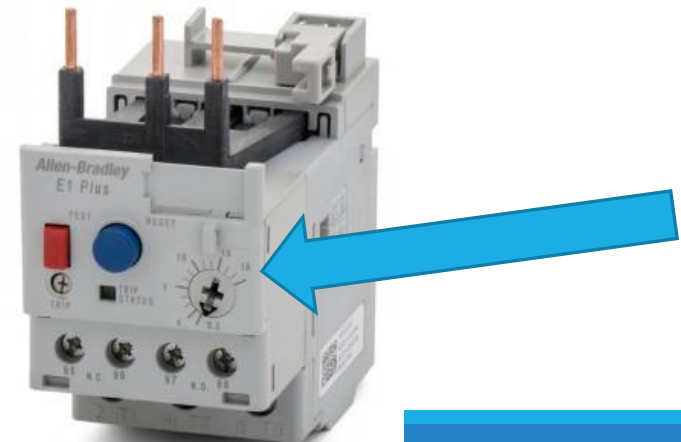

Allen-Bradley  
E1 Plus

TEST

RESET

Test Button



Reset Button

Trip Setting

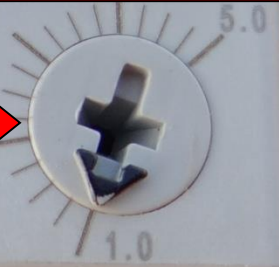

TRIP

STATUS

NC Contact



95 N.C.



96



97

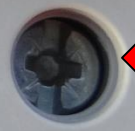

N.O. 98

NO Contact



2 T1



4 T2



6 T3

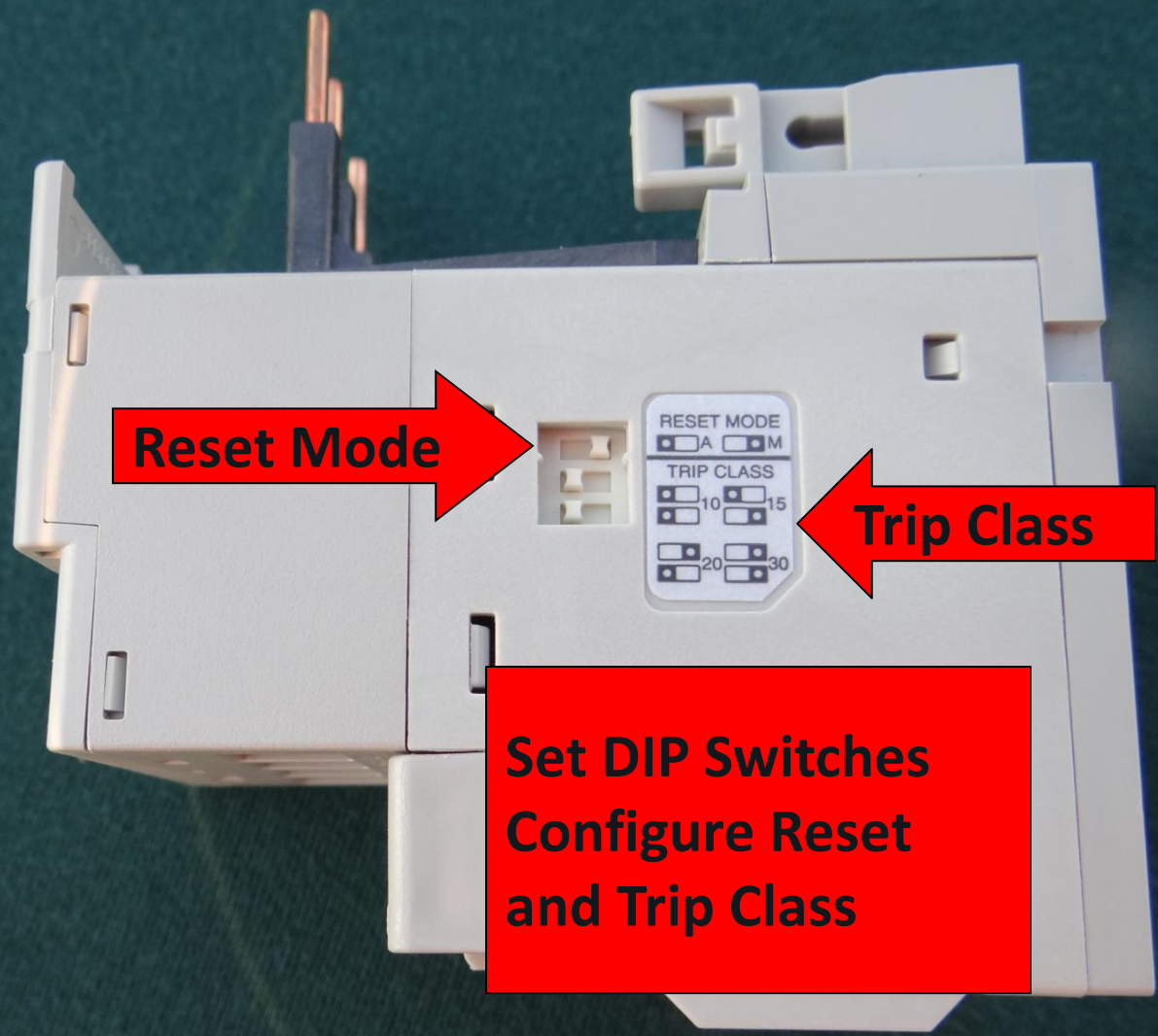

**Reset Mode**

**Trip Class**

**Set DIP Switches  
Configure Reset  
and Trip Class**

RESET MODE  
 A  M  
TRIP CLASS  
 10  15  
 20  30



# Worksheet Example OL setting

Motor Branch Circuit Calculations												
HP	MOTOR	VOLTS	PH	Name Plate Current Rating	Code Book Current Value	Code Letter	Service Factor	Maximum Locked Rotor Current	Minimum Size THWN Conductor	Maximum Trip Setting	Maximum SC & GF Dual-Element Time-Delay Fuse	Minimum Controller Size
75	M-1	460	3	92	96	H	1.15	667	1 AWG			
60	M-2	460	3	68	77	G	1.15	474	3 AWG			
50	M-3	460	3	58	65	G	1.15	395	4 AWG			
40	M-4	460	3	46	52	H	1.00	356	6 AWG			
Motor Feeder Calculations												
Minimum Circuit Ampacity					Minimum Size THWN Conductor					Maximum SC & GF Dual Element, Time Delay Fuse		
314					400 kcmil Cu							



# Worksheet Answers

## Motor Branch Circuit Calculations

HP	MOTOR	VOLTS	PH	Name Plate Current Rating	Code Book Current Value	Code Letter	Service Factor	Maximum Locked Rotor Current	Minimum Size THWN Conductor	Maximum Trip Setting	Maximum SC & GF Dual-Element Time-Delay Fuse	Minimum Controller Size
75	M-1	460	3	92	96	H	1.15	667	1 AWG	115		
60	M-2	460	3	68	77	G	1.15	474	3 AWG	85		
50	M-3	460	3	58	65	G	1.15	395	4 AWG	72.5		
40	M-4	460	3	46	52	H	1.00	356	6 AWG	52.9		

## Motor Feeder Calculations

Minimum Circuit Ampacity	Minimum Size THWN Conductor	Maximum SC & GF Dual Element, Time Delay Fuse
314	400 kcmil Cu	



# Formulas — Approximate Full Load Amps for Other Motors

---

208 Volt Full Load Amp = 230 Volt current  $\times$  110%

Service factor 1.0 = amps  $\times$  0.9

50°C–55°C motor = amps  $\times$  0.9

# 430.36/37/38 – Overload Installation Guidelines



## 430.36 Fuses — In Which Conductor.

Where **fuses are used for motor overload protection, a fuse shall be inserted in each ungrounded conductor** and also in the grounded conductor if the supply system is 3-wire, 3-phase ac with one conductor grounded. (corner grounded Delta)



# 430.37 Devices Other Than Fuses — In Which Conductor

Where devices other than fuses are used for **motor overload protection**, **Table 430.37** shall govern the **minimum allowable number and location of overload units** such as trip coils or relays.



**Table 430.37 Overload Units**

Kind of Motor	Supply System	Number and Location of Overload Units, Such as Trip Coils or Relays
1-phase ac or dc	2-wire, 1-phase ac or dc ungrounded	1 in either conductor
1-phase ac or dc	2-wire, 1-phase ac or dc, one conductor grounded	1 in ungrounded conductor
1-phase ac or dc	3-wire, 1-phase ac or dc, grounded neutral conductor	1 in either ungrounded conductor
1-phase ac	Any 3-phase	1 in ungrounded conductor
2-phase ac	3-wire, 2-phase ac, ungrounded	2, one in each phase
2-phase ac	3-wire, 2-phase ac, one conductor grounded	2 in ungrounded conductors
2-phase ac	4-wire, 2-phase ac, grounded or ungrounded	2, one for each phase in ungrounded conductors
2-phase ac	Grounded neutral or 5-wire, 2-phase ac, ungrounded	2, one for each phase in any ungrounded phase wire
3-phase ac	Any 3-phase	3, one in each phase*

*\*Exception: An overload unit in each phase shall not be required where overload protection is provided by other approved means.*

# 430.37 Devices Other Than Fuses in Which Conductor.



# 430.38 Number of Conductors Opened by Overload Device

Motor overload devices, other than fuses or thermal protectors, shall simultaneously open a sufficient number of ungrounded conductors to interrupt current flow to the motor.

## Part IV



---

# Sizing Motor Short Circuit and Ground Fault Protection

# Definition: Short-Circuit

---



An unintentional, electrically conductive connection of low impedance between conductors of an electrical circuit, or circuit conductors of equipment.

A short-circuit is one of three possible overcurrent conditions.



# Definition: Ground-Fault (NEC)

---

An unintentional, electrically conductive connection between an ungrounded conductor of an electrical circuit and the normally non-current-carrying conductors, metallic enclosures, metallic raceways, metallic equipment, or earth.

A ground-fault is one of three possible overcurrent conditions.



# 430.51/52 – Sizing the Overcurrent Protection

---

## (C) Rating or Setting.

- (1) In Accordance with Table 430.52. A protective device that has a **rating or setting not exceeding the value calculated according to the values given in Table 430.52** shall be used.



# Table 430.52

Type of Motor	Percentage of Full-Load Current				
	Fuse	Nontime Delay Fuse	Dual Element Time-Delay	Instant Trip Breaker	Inverse Time Breaker
Single-phase motors		300	175	800	250
AC polyphase motors other than wound-rotor		300	175	800	250
Squirrel cage — other than Design B energy-efficient		300	175	800	250
Design B energy-efficient:		300	175	1100	250
Synchronous <sup>3</sup>		300	175	800	250
Wound rotor		150	150	800	150
Direct current		150	150	250	150

# Notes to Table 430.52



Note: For certain exceptions to the values specified, see 430.54.

---

1. The values in the **Nontime Delay Fuse** column applies to **Time-Delay Class CC fuses**.
2. The values given in the **last column** also covers the ratings of **nonadjustable inverse time types of circuit breakers** that may be modified as in 430.52(C)(1), Exception No. 1 and No. 2.
3. **Synchronous motors of the low-torque, low-speed type** (usually 450 rpm or lower), such as are used to drive reciprocating compressors, pumps, and so forth, that start unloaded, do not require a fuse rating or circuit-breaker setting in excess of **200 percent** of full-load current.



# 430.52 – Sizing Overcurrent Protection Sample Motor

---

$$40 \times 1.75 = 70 \text{ amps}$$

70-amp **Dual Element Fuse**

Exception 1 would allow going to the next standard OCP device if the calculation does not match a standard size



# Worksheet Short Circuit Protection

## Motor Branch Circuit Calculations

HP	MOTOR	VOLTS	PH	Name Plate Current Rating	Code Book Current Value	Code Letter	Service Factor	Maximum Locked Rotor Current	Minimum Size THWN Conductor	Maximum Trip Setting	Maximum SC & GF Dual-Element Time-Delay Fuse	Minimum Controller Size
75	M-1	460	3	92	96	H	1.15	667	1 AWG	115		
60	M-2	460	3	68	77	G	1.15	474	3 AWG	85		
50	M-3	460	3	58	65	G	1.15	395	4 AWG	72.5		
40	M-4	460	3	46	52	H	1.00	356	6 AWG	52.9		

## Motor Feeder Calculations

Minimum Circuit Ampacity	Minimum Size THWN Conductor	Maximum SC & GF Dual Element, Time Delay Fuse
314	400 kcmil Cu	



# Worksheet **Answers**

## Motor Branch Circuit Calculations

HP	MOTOR	VOLTS	PH	Name Plate Current Rating	Code Book Current Value	Code Letter	Service Factor	Maximum Locked Rotor Current	Minimum Size THWN Conductor	Maximum Trip Setting	Maximum SC & GF Dual-Element Time-Delay Fuse	Minimum Controller Size
75	M-1	460	3	92	96	H	1.15	667	1 AWG	115	175	
60	M-2	460	3	68	77	G	1.15	474	3 AWG	85	150	
50	M-3	460	3	58	65	G	1.15	395	4 AWG	72.5	125	
40	M-4	460	3	46	52	H	1.00	356	6 AWG	52.9	100	

## Motor Feeder Calculations

Minimum Circuit Ampacity	Minimum Size THWN Conductor	Maximum SC & GF Dual Element, Time Delay Fuse
314	400 kcmil	

# Fusetron® Dual-Element, Time-Delay, Class RK5 Fuses



**FRN-R (250V)**

**Dual-Element, Time-Delay – 10 seconds (minimum) at 500% rated current**

**Ampere Ratings: 1/10 - 600 amps**

**Voltage Rating: 250 Volts AC (or less), 125 Volts DC**

**Current Limiting RK5 Fuse**

**Interrupting Rating: 200,000A RMS Sym. (20,000A @ 125V DC)**





# 430.52 – Sizing Overcurrent Protection

## Sample Motor

---

- An RK5 Fuse will handle **500% for 10 seconds**
- $70 \text{ amp} \times 5 = 350 \text{ amps}$ .
- A 70 amp RK5 fuse will carry 350 amps for 10 seconds.
- Inrush current for this motor is 144 amps

**OK to use for sample motor?**

# V. Motor Feeder Short-Circuit and Ground Fault Protection



## 430.62 Rating or Setting — Motor Load.

---

(A) Specific Load. A feeder supplying a specific fixed motor load(s) and consisting of conductor sizes based on 430.24 shall be provided with a protective device having a rating or setting not greater than the largest rating or setting of the branch-circuit short-circuit and ground-fault protective device for any motor supplied by the feeder [based on the maximum permitted value for the specific type of a protective device in accordance with 430.52, or 440.22(A) for hermetic refrigerant motor-compressors], plus the sum of the full-load currents of the other motors of the group.

# V. Motor Feeder Short-Circuit and Ground-Fault Protection

---



## (B) Other Installations.

Where feeder conductors have an ampacity greater than required by 430.24, the rating or setting of the feeder overcurrent protective device shall be permitted to be based on the ampacity of the feeder conductors.



# 430.63 Rating or Setting — Power and Lighting Loads

---

Where a feeder supplies a motor load and, in addition, a lighting, or a lighting and appliance load, the feeder protective device shall have a rating sufficient to carry the lighting or lighting and appliance load, plus the following:

- (1) For a single motor, the rating permitted by 430.52
- (2) For a single hermetic refrigerant motor-compressor, the rating permitted by 440.22
- (3) For two or more motors, the rating permitted by 430.62

*Exception: Where the feeder overcurrent device provides the overcurrent protection for a motor control center, the provisions of 430.94 shall apply.*

# Calculate the feeder conductor and overcurrent protection

---



7.5 HP, 230 V, 20A, three phase, SF 1.0, Cont. Duty, Design B, Code R, 1725 RPM, 60Hz,

30 HP, 230 V, 78A, SF.1.15, Cont. Duty, Design B, Code D, 1150 RPM, 60HZ

# Calculate the feeder conductor and overcurrent protection

---



Table 430.250 Values for: 7.5 HP = 22A  
30 HP = 80A

$$80 \times 1.25 = 100 \text{ amps} + 22 = 122 \text{ A}$$

122 amps = 1 AWG Feeder Conductor

# Calculate the feeder conductor and overcurrent protection



Table 430.250 Values for: 7.5 HP = 22 A

30

$$\text{HP} = 80 \text{ A}$$

$$80 \times 1.75 = 140 \text{ amp}$$

430.52 E  $\times$  1 allows to go up to the next standard size =  
150 amps

$$150 \text{ amps} + 22 = 172 \text{ amps} \downarrow = 150 \text{ Amp OCP}$$



# Worksheet Feeder Protection

## Motor Branch Circuit Calculations

HP	MOTOR	VOLTS	PH	Name Plate Current Rating	Code Book Current Value	Code Letter	Service Factor	Maximum Locked Rotor Current	Minimum Size THWN Conductor	Maximum Trip Setting	Maximum SC & GF Dual-Element Time-Delay Fuse	Minimum Controller Size
75	M-1	460	3	92	96	H	1.15	667	1 AWG	115	175	
60	M-2	460	3	68	77	G	1.15	474	3 AWG	85	150	
50	M-3	460	3	58	65	G	1.15	395	4 AWG	72.5	125	
40	M-4	460	3	46	52	H	1.00	356	6 AWG	52.9	100	

## Motor Feeder Calculations

Minimum Circuit Ampacity	Minimum Size THWN Conductor	Maximum SC & GF Dual Element, Time Delay Fuse
314	400 kcmil	

# Worksheet Answers



## Motor Branch Circuit Calculations

HP	MOTOR	VOLTS	PH	Name Plate Current Rating	Code Book Current Value	Code Letter	Service Factor	Maximum Locked Rotor Current	Minimum Size THWN Conductor	Maximum Trip Setting	Maximum SC & GF Dual-Element Time-Delay Fuse	Minimum Controller Size
75	M-1	460	3	92	96	H	1.15	667	1 AWG	115	175	
60	M-2	460	3	68	77	G	1.15	474	3 AWG	85	150	
50	M-3	460	3	58	65	G	1.15	395	4 AWG	72.5	125	
40	M-4	460	3	46	52	H	1.00	356	6 AWG	52.9	100	

## Motor Feeder Calculations

Minimum Circuit Ampacity	Minimum Size THWN Conductor	Maximum SC & GF Dual Element, Time Delay Fuse
314	400 kcmil	350



# END PART 1

(2 of 4 hours)

---



# Motor Installation Requirements Based on 2020 NEC Part 2

Presented by: Electrical Association  
Of Minnesota

To access the course PowerPoints visit:  
[www.electricalassociation.com/powerpoints](http://www.electricalassociation.com/powerpoints)



# Part 2

## 2-hour Code credit

---

### Motors and Associated Electrical Code

This course offering is recognized by the Minnesota Department of Labor and Industry as satisfying 2 hours of electrical code credit for continuing education.

Copyright 2019 Minnesota Electrical association



# DISCLAIMER

---

“Through the presentation of this course and/or these materials no representation actual or implied is made that the trainer or MEA/ETN is setting or enforcing specific standards or is providing peer review, certification, accreditation, or product testing”.

**Use of NFPA Document 70-NEC®:**

**IACET requirements**



# Learning outcomes

Upon completion of this course, the students will be able to do the following tasks to demonstrate skills within industry standards.

- Choose the correct ratings of motor controller
- Describe the differences between IEC and NEMA controllers
- Complete worksheet for NEMA Controllers
- Describe location requirements for motor disconnects
- Determine the ratings of motor disconnects



# Learning outcomes- Continued

Upon completion of this course, the students will be able to do the following tasks to demonstrate skills within industry standards.

- Review the grounding requirements for motors and motor systems
- Describe the methods for grounding
- Determine the size of grounding conductors
- Complete the worksheets for grounding motors
- Determine the correct size of conduits for motor wiring
- Describe how to find circuit conductors used for motor control
- Explain how capacitors are sized based on power factor correction needs
- Describe the requirements needed for special motor installation
- Review the requirements for adjustable speed drives (VFDs)

# Part VII – 430.81/82 – Sizing the Controller



The controller shall have a rating as specified in 430.83(A), unless otherwise permitted in 430.83(B) or (C), or as specified in (D), under the conditions specified. Part (E) voltage ratings of controllers.



# Definition: Controller (NEC)

For the purpose of Article 430, a controller is any switch or device that is normally used to start and stop a motor by making or breaking the motor circuit current.



Single pole switch



Inverse time circuit breaker

# 430.83 – Sizing the Controller



## (A) General

---

- (1) Horsepower Ratings. Controllers, other than inverse time circuit breakers and molded case switches, **shall have horsepower ratings** at the application voltage not lower than the horsepower rating of the motor.
- (2) Circuit Breaker. **A branch-circuit inverse time circuit breaker rated in amperes shall be permitted** as a controller for all motors. Where this circuit breaker is also used for overload protection, it shall conform to the appropriate provisions of this article governing overload protection.
- (3) Molded Case Switch. A **molded case switch rated in amperes shall be permitted** as a controller for all motors.

---

# Molded Case Switch





# Motor Nameplate Information for sample calculations



---

**30HP, 460V, 38A, 3Ø, S.F. 1.15,  
40°C AMB., Code G, Design B, Cont. Duty, 1725 RPM, 60Hz,  
Ins. Class B.**

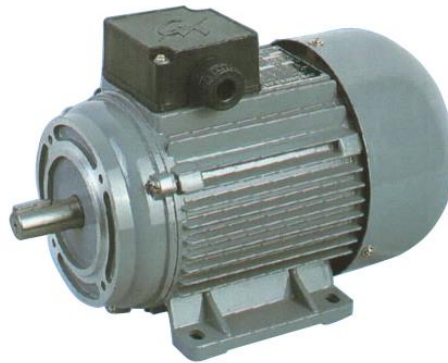

# 430.82 – Sizing the Controller



For example motor - 30 Horsepower Rated Controller: NEMA size 3 for 460V 3 phase

- AC-1 for purely resistive or only slightly inductive loads, such as heater circuits
- AC-3 for routine starting and stopping of a squirrel cage motor and only occasional jogging
- AC-4 is similar to AC-3 but includes inching and plugging (jogging and reversing at speed), requiring significant instantaneous control of the motor current



IEC with AC-3 rating

**Figure 1.** This NEMA starter and IEC starter are each sized for up to a 27-amp load, with the NEMA starter capable of a wider range of duty befitting its larger size and greater weight.

# Controller Sizing –NEMA



## Manufacture Table

Maximum HORSEPOWER 3 PHASE MOTORS												
NEMA SIZE	Full Voltage Starting			Auto Transformer Starting			Part Winding Starting			WYE - Delta Starting		
	200V	230V	460V 575V	200V	230V	460V 575V	200V	230V	460V 575V	200V	230V	460V 575V
<b>00</b>	1.5	1.5	2	--	--	--	--	--	--	--	--	--
<b>0</b>	3	3	5	--	--	--	--	--	--	--	--	--
<b>1</b>	7.5	7.5	10	7.5	7.5	10	10	10	15	10	10	15
<b>2</b>	10	15	25	10	15	25	20	25	40	20	25	40
<b>3</b>	25	30	50	25	30	50	40	50	75	40	50	75
<b>4</b>	40	50	100	40	50	100	75	75	150	60	75	150
<b>5</b>	75	100	200	75	100	120	150	150	350	150	150	300
<b>6</b>	150	200	400	150	200	400	--	--	--	--	--	--

# Example Sizing for IEC controller

## Three-Pole Contactors, Frame D—IEC Ratings

AC-3 $I_e$ (A)	AC-1 (40°C) $I_e = I_{th}$ (A)	Maximum kW Ratings AC-3/Three-Phase Motors 50–60 Hz				Auxiliary Contacts	Screw Terminal Catalog Number <sup>①②</sup>
		220/230V	380/400V	415V	660/690V		
40	60	12.5	18.5	24	23	—	XTCE040D00_
40	60	12.5	18.5	24	23	1NO-1NC	XTCE040DS1_
50	80	15.5	22	30	30	—	XTCE050D00_
50	80	15.5	22	30	30	1NO-1NC	XTCE050DS1_
65	98	20	30	39	35	—	XTCE065D00_
65	98	20	30	39	35	1NO-1NC	XTCE065DS1_
72	98	22	37	41	35	—	XTCE072D00_
72	98	22	37	41	35	1NO-1NC	XTCE072DS1_

# Motor circuit protectors for disconnect and short circuit protection



## Motor Circuit Protectors

### Product Overview



#### Bulletin 140M Motor Circuit Protectors

- Current range 0.16...1200 A
- UL Listed/Recognized for motor loads
  - Short-circuit protection
  - Overload protection must be provided separately
- Visible trip indication
- High current limiting
- High switching capacity

The Bulletin 140M Motor Circuit Protectors provide short circuit protection for individual motor loads. Factory-installed internal accessories make installation and wiring easy.

#### Certifications (0.16...45 A)

CE Marked  
cULus Listed (File No. E54612,  
Guide No. NLRV, NLRV7)  
CCC

#### Certifications (3...1200 A)

UR Recognized component  
(File No. E224135, Guide  
DKPU2)  
CSA Certified (Class No.  
3211-07)

#### Table of Contents

Product Selection — Motor Circuit Protectors .....	2-16
Approximate Dimensions.....	2-51

#### Standards Compliance

IEC/EN 60947-1, 2, -4-1, -5-1  
IEC/EN 60204-1  
CSA, C22.2 No.14  
UL 508  
UL 489 (H-, J-, L-, N-Frame)

### General Information

Motor Circuit Protectors may provide the following protective and control functions.

- Disconnect for Motor Branch Circuit
- Branch-Circuit, Short-Circuit Protection (Magnetic Protection)
- Switching (Manual)

In North America, electrical codes require that an individual Motor Branch Circuit be protected by a UL/CSA Listed Fuse, Circuit Breaker or Self-Protected Combination Motor Controller.

# NEMA vs. IEC Controller comparison



## Overloads and single phasing

Although either IEC or NEMA components can be used in most every motor protection scheme, there are significant differences between the two standards regarding protection from thermal overload or single-phase conditions. Solid-state or electronic overload relays have become a popular solution for both IEC and NEMA starter applications, and these relays are significantly different from standard NEMA thermoelectric overload devices.

The standard NEMA overload relay uses bimetallic or eutectic alloy overloads. Electronic overloads deliver superior performance, but are usually offered as an option at additional costs. The standard overload relay uses removable heaters to actuate the protective relay, which must be manually reset at the device after a trip. But with electronic overloads, built-in automatic reset can be activated once an operator has confirmed a safe condition.

Another significant difference between IEC and NEMA overload relays is phase loss detection. This critical motor protective feature is standard on IEC starters, but must be added to a standard NEMA starter.

# IEC vs. NEMA cost and size



---

IEC is usually less expensive.	NEMA can better withstand overloads.
IEC takes up significantly less space.	NEMA requires less precision in design.
IEC starter includes single-phase detection.	NEMA is better for applications with load uncertainties.
IEC starter provides quicker detection of overload conditions.	NEMA can more easily withstand short circuits.
IEC is finger safe.	NEMA is more rugged and can better withstand abuse.

# IEC vs. NEMA differences



- Poor selection of short-circuit/ground fault protection upstream of the IEC starter causes more welded contacts and “self-destructed” units than occurs with comparable NEMA components, but type 2 coordination can minimize this problem. Type 2 coordination is a protection category described in IEC 60947-4-1. Section 8.2.5.1 specifies that type 2 coordination requires that under short-circuit conditions, the starter shall cause no danger to persons or installations and shall be suitable for further use.

## Caveats

A common method many use to reduce failure concerns of IEC devices is to upsize the starter to the next range. This gives about 30 percent extra capacity, and works well according to many experienced engineers and electricians. For example, an IEC starter for a 10-hp, 480-V motor could be upsized to a 25-A device, making it comparable to a NEMA size 1 rating. This also saves more than 11 square inches of panel space.



# Worksheet NEMA controller size

## Motor Branch Circuit Calculations

HP	Motor	Volts	PH	Name-plate Current Rating	Code Letter	Service Factor	Maximum Locked-Rotor Current	Minimum Size THWN Conductor	AB 193-E1 Plus Overload Maximum Dial Setting	Maximum SC & GF Dual-Element Time-Delay Fuse	Minimum Controller Size
75	M-1	460	3	92	H	1.15	667	1 AWG	92	175	
60	M-2	460	3	68	G	1.15	474	3 AWG	68	150	
50	M-3	460	3	58	G	1.15	395	4 AWG	58	125	
40	M-4	460	3	46	H	1.00	356	6 AWG	41.4	100	

## Motor Feeder Calculations

Minimum Circuit Ampacity	Minimum Size THWN Conductor	Maximum SC & GF Dual-Element, Time-Delay, Fuse
314	400 kcmil	



# Worksheet Answers

## Motor Branch Circuit Calculations

HP	Motor	Volts	PH	Name-plate Current Rating	Code Letter	Service Factor	Maximum Locked-Rotor Current	Minimum Size THWN Conductor	AB 193-E1 Plus Overload Maximum Dial Setting	Maximum SC & GF Dual-Element Time-Delay Fuse	Minimum Controller Size
75	M-1	460	3	92	H	1.15	667	1 AWG	92	175	4
60	M-2	460	3	68	G	1.15	474	3 AWG	68	150	4
50	M-3	460	3	58	G	1.15	395	4 AWG	58	125	3
40	M-4	460	3	46	H	1.00	356	6 AWG	41.4	100	3

## Motor Feeder Calculations

Minimum Circuit Ampacity	Minimum Size THWN Conductor	Maximum SC & GF Dual-Element, Time-Delay, Fuse
314	400 kcmil	350



# Part IX – 430.109/110 – Sizing the Disconnect

## 430.109

---

The disconnecting means shall be a type specified in 430.109(A), unless otherwise permitted in 430.109(B) through (G), under the conditions specified.

# 430.109/110 – Sizing the Disconnect



## (A) General.

---

- (1) **Motor Circuit Switch.** A listed motor-circuit switch rated in horsepower.
- (2) **Molded Case Circuit Breaker.** A listed molded case circuit breaker.
- (3) **Molded Case Switch.** A listed molded case switch.
- (4) **Instantaneous Trip Circuit Breaker.** An instantaneous trip circuit breaker that is part of a listed combination motor controller.
- (5) **Self-Protected Combination Controller.** Listed self-protected combination controller.
- (6) **Manual Motor Controller.** Listed manual motor controllers marked “Suitable as Motor Disconnect” shall be permitted as a disconnecting means where installed between the final motor branch-circuit short-circuit protective device and the motor.

# Self-Protected Combination Controller

## Manual Self Protected Combination Motor Controller Type E

### Application

- For systems comprising one or several motors

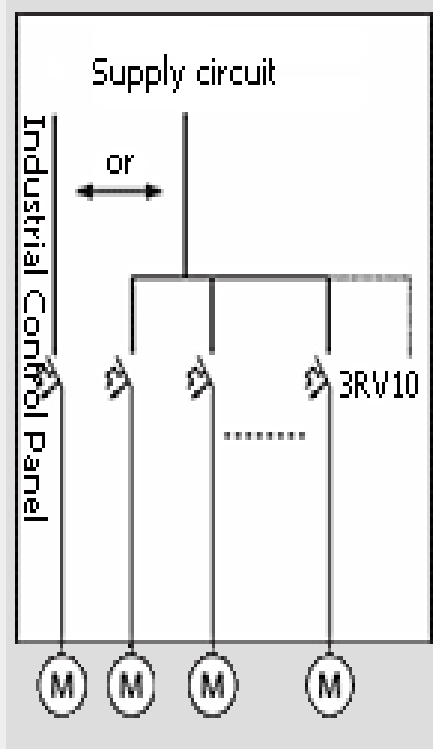

Devices	ULstandard	Device functions			
		Disconnect	Short-circuit protection	Motor control	Overload protection
Manual Self Protected Combination Motor Controller	UL 508	o	o	o	o

# Self-Protected Combination Controller



---

The LMR32 motor controllers have rotating handle operation and are suitable also as motor disconnect according to standards. Their high short-circuit rating allows us to exclude protection fuses and/or circuit breakers on the majority of the installations



# Part IX – 430.110

## Sizing the Disconnect

---



(A) General. The disconnecting means for motor circuits rated 600 volts, nominal, or less **shall have an ampere rating not less than 115 percent of the full-load current rating of the motor.** (code book value)

(B) For Torque Motors. Disconnecting means for a torque motor shall have an ampere rating of at least 115 percent of the motor nameplate current.

# 430.109/110 – Sizing the Disconnect

For example motor:

430.109 – 30 Horsepower (generally)

430.110 –  $40 \times 1.15 = 46$  amps

60 amp switch needed



# Standard Sizes of Disconnect Switches



## Example from Siemens

### Ordering Information

1. Select the basic switch size you need (30, 60, 100 or 200 ampere).
2. Check the switch selected against the maximum horsepower rating required for our application. "L" or "R" suffix on

switch catalog numbers denotes left or right-handed mechanism drive.

3. Choose either fuse or no fuse kit from chart below.
4. Check "Minimum Dimensions" on page

5. Select from the list of handle operators, the type which best suits your application. Handle operators can be selected from the next page.

### Basic Switches

Switch Ampere Rating	Maximum Voltage Rating	Catalog Number Right Hand	Catalog Number Left Hand	Maximum Horsepower Rating, 3 Phase <sup>④</sup>						250 Volts DC (max) <sup>④</sup>
				240 Volts AC		480 Volts AC		600 Volts AC		
				Standard Fuse	Time Delay Fuse	Standard Fuse	Time Delay Fuse	Standard Fuse	Time Delay Fuse	
30	600	MCS603R	MCS603L	3	7½	5	15	7½	20	5
60	600	MCS606R	MCS606L	7½	15	15	30	15	50	10
100	600	MCS610R	MCS610L▲	15	30	25	60	30	75	20
200	600	MCS620R	MCS620L▲	25	60	50	125	60	150	40

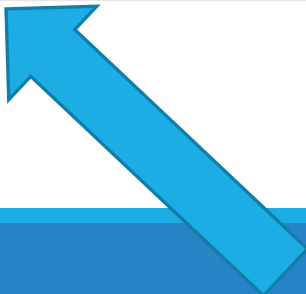

# Part XIII – 430. 242 – Sizing the Grounding Conductor for Stationary Motors



The frames of stationary motors shall be grounded under any of the following conditions:

- (1) Where supplied by metal-enclosed wiring
- (2) Where in a wet location and not isolated or guarded
- (3) If in a hazardous (classified) location
- (4) If the motor operates with any terminal at over 150 volts to ground

Where the frame of the motor is not grounded, it shall be permanently and effectively insulated from the ground.



# 430.245 Method of Grounding.

---

Connection to the equipment grounding conductor shall be done in the manner specified in Part VI of Article 250.

# Grounding conductors from table 250.122



For sample 30 HP motor

---

OCP is 70 amps

Using **Table 250.122** and OC protection

**8 AWG CU**

# Worksheet for EGC



## Motor Branch Circuit Calculations

HP	Motor	Volts	PH	Name-plate Current Rating	Code Letter	Service Factor	Maximum Locked-Rotor Current	Minimum Size THWN Conductor	AB 193-E1 Plus Overload Maximum Dial Setting	Maximum SC & GF Dual-Element Time-Delay Fuse	Minimum Size Equipment Grounding Conductor
75	M-1	460	3	92	H	1.15	667	1 AWG	92	175	
60	M-2	460	3	68	G	1.15	474	3 AWG	68	150	
50	M-3	460	3	58	G	1.15	395	4 AWG	58	125	
40	M-4	460	3	46	H	1.00	356	6 AWG	41.4	100	

## Motor Feeder Calculations

Minimum Circuit Ampacity	Minimum Size THWN Conductor	Maximum SC & GF Dual-Element, Time-Delay, Fuse
314	400 kcmil	350

# Worksheet Answers



## Motor Branch Circuit Calculations

HP	Motor	Volts	PH	Name-plate Current Rating	Code Letter	Service Factor	Maximum Locked-Rotor Current	Minimum Size THWN Conductor	AB 193-E1 Plus Overload Maximum Dial Setting	Maximum SC & GF Dual-Element Time-Delay Fuse	Minimum Size Equipment Grounding Conductor
75	M-1	460	3	92	H	1.15	667	1 AWG	92	175	6 AWG
60	M-2	460	3	68	G	1.15	474	3 AWG	68	150	6 AWG
50	M-3	460	3	58	G	1.15	395	4 AWG	58	125	6 AWG
40	M-4	460	3	46	H	1.00	356	6 AWG	41.4	100	8 AWG

## Motor Feeder Calculations

Minimum Circuit Ampacity	Minimum Size THWN Conductor	Maximum SC & GF Dual-Element, Time-Delay, Fuse
314	400 kcmil	350



# Sizing Motor Conductor Raceway FMC using Chapter 9, Tables 1,4,5,8

---

## Option 1:

Using Table 5, Chapter 9

**8 AWG THW** =  $0.0437 \times 4 = 0.1748$  sq in

Using Table 4 (FMC) the 40% fill column

At 0.213 for a **3/4" Flexible Metal Conduit**

## Option 2:

Use Table Annex "C" Table C.3 (THW conductor)

**3/4" Flexible Metal Conduit**



# Part VI – Motor Control Circuits

---

## Table 430.72(B)

Maximum Rating of Overcurrent Protective Device in Amperes for  
Motor Control Circuit conductors



# Definition: Control Circuit (NEC)

---

The circuit of a control apparatus or system that carries the electric signals directing the performance of the controller but does not carry the main power current.

# 430.72 B conductor protection



- 
- (B)(1) Separate overcurrent protection is based on Table 430.72(B) column A
  
  - (B)(2) Table 430.72(B) column B or C for protection from the motor short circuit protection

# Tapped From the Load-side of the SC & GF Protection with OCPD

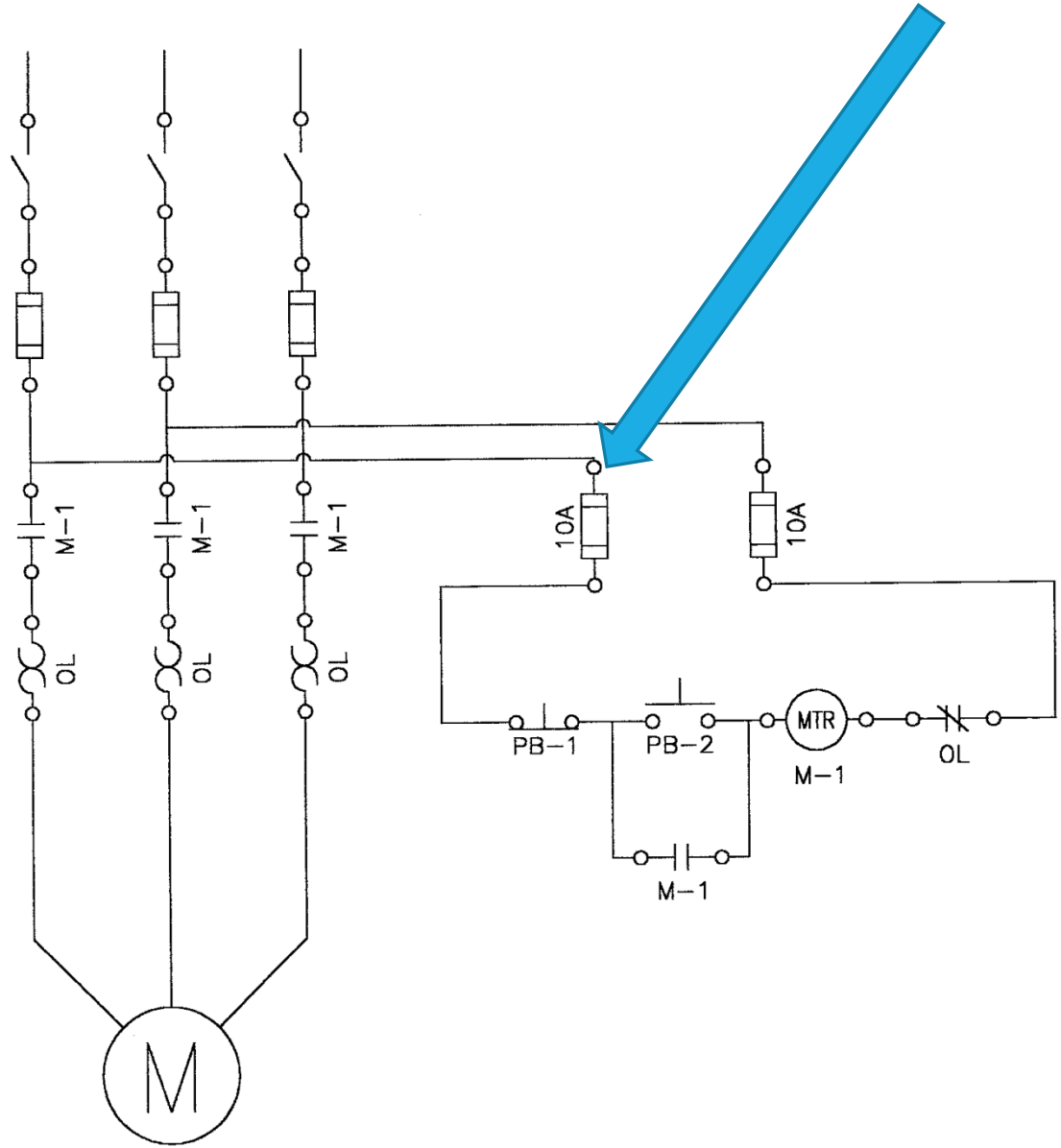



# Column A from 430.72 B

Given: The motor control circuit is supplied by the motor branch circuit.

---

A motor control circuit consists of 16 AWG copper conductors and extends beyond the controller enclosure. The branch circuit protective device is rated at 60 amperes. What is the maximum rating of the protective device for the control circuit?

10 amperes per Column C of Table 430.72(B)

# Tapped From the Load side of the SC & GF Protection w/o OCPD

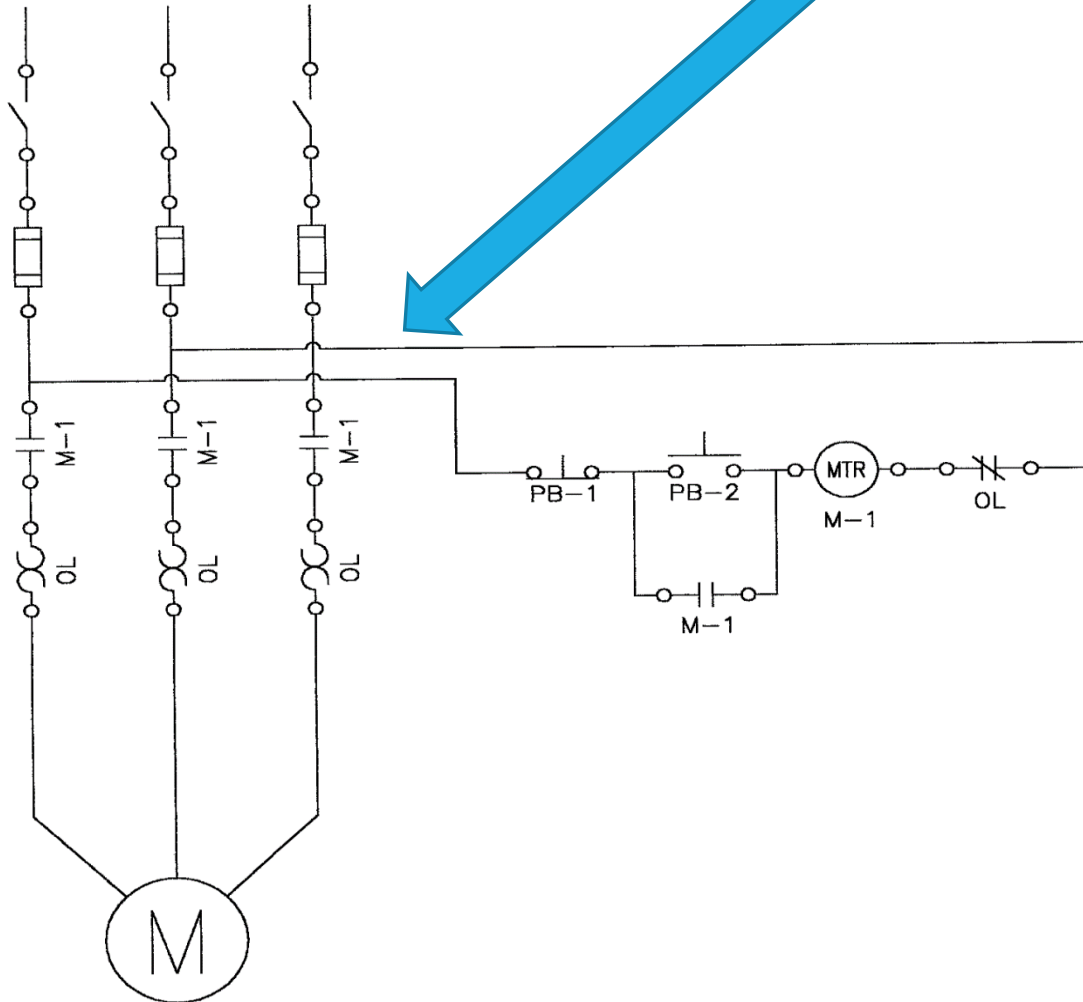



# Column B of 430.72 B

Given: The motor control circuit is supplied by the motor branch circuit.

---

A motor control circuit consists of 16 AWG copper conductors and do not extend beyond the controller enclosure. What is the maximum rating of the branch circuit protective device that would provide proper protection for the control circuit?

40 amperes per Column B of Table 430.72(B)



# Column C of 430.72 B

Given: The motor control circuit is supplied by the motor branch circuit.

A motor control circuit consists of 14 AWG copper conductors and extends beyond the controller enclosure. What is the maximum rating of the branch circuit protective device that would provide proper protection for the control circuit?

45 amperes per Column C of Table 430.72(B)



# 430.72(C) Control Circuit Transformer

---

When using a Control circuit transformer, the transformer shall be protected as in C1- C5

# Sample single motor installation 7.5 HP motor



---

7.5 HP, 230 V, 20A, three-phase, SF 1.0, Cont. Duty, Design B, Code R, 1725 RPM, 60Hz, Size:

Conductor (75°C)

OL trip current rating

OCP (Dual Element)

Controller

Disconnect (Current Rating)

Equipment Grounding Conductor

Type LFMC

# 30 HP, 3 $\phi$ , 230 V, 75A, SF.1.15, cont. duty, Design B, Code D, 1150RPM, 60HZ



Size the following for the motor installation:

---

Conductor (THW):  $125\% \times 80A = 100A - 3 \text{ AWG}$

OL trip current rating:  $125\% \times 75 \text{ A} = 93.75A$

OCP (Dual Element):  $175\% \times 80 = 140A/150A$

Controller: NEMA 3 (30HP @ 230V)

Disconnect (Current Rating):  $115\% \times 80 = 92A / 100A$  but fuse is 150A for fused dis.

Grounding conductor: 6 AWG

LFMC:  $3 \times 3 \text{ AWG} + 6 \text{ AWG} = 1\frac{1}{4}$



---

# **Article 430 Special Applications and Installation Adjustments**

# 430.27 Capacitors with Motors



Where capacitors are installed in motor circuits, conductors shall comply with 460.8 and 460.9.



# Art 460 - Related to Art. 430

---

Capacitors used with motor power factor correction

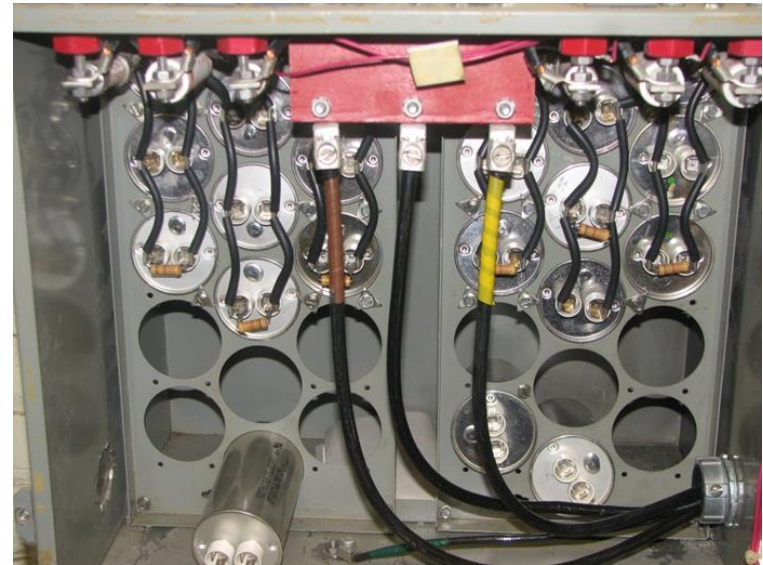

# 460.6 Discharge of Stored Energy



Capacitors shall be provided with a means of discharging stored energy.

**(A) Time of Discharge.** The residual voltage of a capacitor shall be reduced to 50 volts, nominal, or less within 1 minute after the capacitor is disconnected from the source of supply.

**(B) Means of Discharge.** The discharge circuit shall be either permanently connected to the terminals of the capacitor or capacitor bank or provided with automatic means of connecting it to the terminals of the capacitor bank on removal of voltage from the line. **Manual means of switching or connecting the discharge circuit shall not be used.**

# 460.8 Capacitor Conductors



(A) **Ampacity.** The ampacity of capacitor circuit conductors shall not be less than 135 percent of the rated current of the capacitor.

The ampacity of conductors that connect a capacitor to the terminals of a motor or to motor circuit conductors shall not be less than one-third the ampacity of the motor circuit conductors and in no case less than 135 percent of the rated current of the capacitor.



# Capacitor OC Protection

**(B) Overcurrent Protection.** An overcurrent device **shall be provided in each ungrounded conductor** for each capacitor bank. The rating or setting of the overcurrent device shall be as low as practicable.

*Except as permitted in the exception to 460.8(B), it is intended that the overcurrent device be separate from the overcurrent device protecting any other equipment or conductor.*

*Exception: A separate overcurrent device shall not be required for a capacitor connected on the load side of a motor overload protective device.*



# 460.8 Conductors

(C) Disconnecting Means. A disconnecting means shall be provided in each ungrounded conductor for each capacitor bank and shall meet the following requirements:

- (1) The disconnecting means shall open all ungrounded conductors simultaneously.
- (2) The disconnecting means shall be permitted to disconnect the capacitor from the line as a regular operating procedure.
- (3) The rating of the disconnecting means shall not be less than 135 percent of the rated If a motor current of the capacitor.

*Exception: A separate disconnecting means shall not be required where a capacitor is connected on the load side of a motor controller.*

# 460.9 Rating or Setting of Motor Overload Device



Where a motor installation includes a capacitor connected on the load side of the motor overload device, the rating or setting of the motor overload device shall be based on the improved power factor of the motor circuit.

The effect of the capacitor shall be disregarded in determining the motor circuit conductor rating in accordance with 430.22.

# 430.4 – Part Winding Motor Requirements Definition

---

- A **part-winding start induction or synchronous motor** is arranged for starting by first energizing part of its primary (armature) winding and, subsequently, energizing the remainder of this winding in one or more steps.
- A **standard part-winding start induction motor** is arranged so that one-half of its primary winding can be energized, and subsequently, the remaining half can be energized, both halves then carrying equal current.

# Part Winding Starters



---

Where separate overload devices are used with a standard part-winding start induction motor, **each half of the motor winding shall be individually protected in accordance with 430.32 and 430.37 with a trip current one-half that specified.**

Each motor-winding connection **shall have branch-circuit short-circuit and ground-fault protection rated at not more than one-half that specified by 430.52.**

# 430.6 – Adjustable Voltage Motor Requirements



---

(C) Alternating-Current Adjustable Voltage Motors. For motors used in alternating-current, adjustable voltage, variable torque drive systems, **the ampacity of conductors, or ampere ratings of switches, branch-circuit short-circuit and ground-fault protection, and so forth, shall be based on the maximum operating current marked on the motor or control nameplate, or both.**

If the maximum operating current does not appear on the nameplate, the ampacity determination shall be based on 150 percent of the values given in Table 430.249 and Table 430.250.

# 430.22 – Conductor requirements for different motors and applications



---

(B) **Multispeed Motor.** For a multispeed motor, the selection of **branch-circuit conductors on the line side of the controller shall be based on the highest of the full-load current ratings shown on the motor nameplate.**

The selection of branch-circuit **conductors between the controller and the motor shall be based on the current rating of the winding(s) that the conductors energize.**

(C) **Wye-Start, Delta-Run Motor.** For a wye-start, delta-run connected motor, the **selection of branch-circuit conductors on the line side of the controller shall be based on the motor full-load current.**

The selection of **conductors between the controller and the motor shall be based on 58 percent of the motor full-load current.**



# 430.22 – Conductor requirements for different motors and applications

---

- (D) **Part-Winding Motor.** For a part-winding connected motor, the selection of branch-circuit conductors on the line side of the controller shall be based on the motor full-load current.

The selection of conductors between the controller and the motor shall be based on 50 percent of the motor full-load current.

- (E) **Other Than Continuous Duty.** Conductors for a motor used in a short-time, intermittent, periodic, or varying duty application shall have an ampacity of not less than the percentage of the motor nameplate current rating shown in Table 430.22(E), unless the authority having jurisdiction grants special permission for conductors of lower ampacity.



# 430.25 Multimotor and Combination-Load Equipment

---

The ampacity of the conductors supplying multimotor and combination-load equipment shall not be less than the minimum circuit ampacity marked on the equipment in accordance with 430.7(D).

Where the equipment is not factory-wired and the individual nameplates are visible in accordance with 430.7(D)(2), the conductor ampacity shall be determined in accordance with 430.24.

# 430.42 – Multiple Motors on a Branch Circuit



Overload protection for motors used on general-purpose branch circuits as permitted in Article 210 shall be provided as specified in 430.42(A), (B), (C), or (D).

- (A) Not over 1 Horsepower. One or more motors without individual overload protection shall be permitted to be connected to a general-purpose branch circuit only where the installation complies with the limiting conditions specified in 430.32(B) and 430.32(D) and 430.53(A)(1) and (A)(2).
- (B) Over 1 Horsepower. Motors of ratings larger than specified in 430.53(A) shall be permitted to be connected to general-purpose branch circuits only where each motor is protected by overload protection selected to protect the motor as specified in 430.32. Both the controller and the motor overload device shall be approved for group installation with the short-circuit and ground-fault protective device selected in accordance with 430.53.

# Circuit 430.42 – Multiple Motors on a Branch



- (C) Cord-and-Plug-Connected. Where a motor is connected to a branch circuit by means of an attachment plug and a receptacle or a cord connector, and individual overload protection is omitted as provided in [430.42\(A\)](#), the rating of the attachment plug and receptacle or cord connector shall not exceed 15 amperes at 125 volts or 250 volts.

Where individual overload protection is required as provided in [430.42\(B\)](#) for a motor or motor-operated appliance that is attached to the branch circuit through an attachment plug and a receptacle or a cord connector, the overload device shall be an integral part of the motor or of the appliance.

The rating of the attachment plug and receptacle or the cord connector shall determine the rating of the circuit to which the motor may be connected, as provided in [210.21\(B\)](#).

# 430.52 – Additional OCP Allowances

---



(B) All Motors. The motor branch-circuit short-circuit and ground-fault protective devices shall be capable of carrying the starting current of the motor.

(C) Rating or Setting.

(1) A protective device that has a rating or setting not exceeding the value calculated according to the values given in Table 430.52 shall be used.

# 430.52 – Additional OCP Allowances



**Exception No. 1:** Where the values for branch-circuit short-circuit and ground-fault protective devices determined by Table 430.52 do not correspond to the standard sizes or ratings of fuses, nonadjustable circuit breakers, thermal protective devices, or possible settings of adjustable circuit breakers, a higher size, rating, or possible setting that does not exceed the next higher standard ampere rating shall be permitted.

**Exception No. 2:** Where the rating specified in Table 430.52, or the rating modified by Exception No. 1, is not sufficient for the starting current of the motor:

- (a) The rating of a nontime-delay fuse not exceeding 600 amperes or a time-delay Class CC fuse shall be permitted to be increased but shall in no case exceed 400 percent of the full-load current.
- (b) The rating of a time-delay (dual-element) fuse shall be permitted to be increased but shall in no case exceed 225 percent of the full-load current.
- (c) The rating of an inverse time circuit breaker shall be permitted to be increased but shall in no case exceed 400 percent for full-load currents of 100 amperes or less or 300 percent for full-load currents greater than 100 amperes.
- (d) The rating of a fuse of 601–6000 ampere classification shall be permitted to be increased but shall in no case exceed 300 percent of the full-load current.

# 430.52 Rating or Setting for Individual Motor Circuit



---

(2) **Overload Relay Table.** Where maximum branch-circuit short-circuit and ground-fault protective device ratings are shown in the **manufacturer's** overload relay table for use with a motor controller or are otherwise marked on the equipment, **they shall not be exceeded even if higher values are allowed as shown above (in table 430.52 and exceptions).**

# 430.54 – Motor and Other Loads on a Branch Circuit



## Multimotor and Combination-Load Equipment.

---

The rating of the branch-circuit short-circuit and ground-fault protective device for multimotor and combination-load equipment shall not exceed the rating marked on the equipment in accordance with 430.7(D).

# 430.81 – Small Motor Allowances for Controllers

---



(A) Stationary Motor of 1/8 hp or Less.

For a stationary motor rated at 1/8 hp or less that is normally left running and is constructed so that it cannot be damaged by overload or failure to start, such as clock motors and the like, the branch-circuit disconnecting means shall be permitted to serve as the controller.

(B) Portable Motor of 1/3 hp or Less.

For a portable motor rated at 1/3 hp or less, the controller shall be permitted to be an attachment plug and receptacle.

# 430.83 – Slash Rated Equipment



- 
- (E) Voltage Rating. A controller with a **straight voltage rating, for example, 240 V or 480 V**, shall be permitted to be applied in a circuit where the **voltage between any two conductors does not exceed the controller's voltage rating**.

A controller with a slash rating, **120/240 V or 480Y/277 V**, shall only be applied in a solidly grounded circuit in which the **voltage to ground from any conductor does not exceed the lower of the two values of the controller's voltage rating**, and the **voltage between any two conductors does not exceed the higher value of the controller's voltage rating**.

# 430.84 Controller Need Not Open All Conductors



---

The controller shall not be required to open all conductors to the motor.

Exception: Where the controller serves also as a disconnecting means, it shall open all ungrounded conductors to the motor as provided in 430.111.

# 430.102 - Controller and Disconnect location requirements



---

A) Controller. An individual disconnecting means shall be provided for each controller and shall disconnect the controller. The disconnecting means shall be located in sight from the controller location.

*Exception No. 2: A single disconnecting means shall be permitted for a group of coordinated controllers that drive several parts of a single machine or piece of apparatus. The disconnecting means shall be located in sight from the controllers, and both the disconnecting means and the controllers shall be located in sight from the machine or apparatus.*

# 430.102 - Controller and disconnect location requirements

---



Exception No. 3: The disconnecting means shall not be required to be in sight from valve actuator motor (VAM) assemblies containing the controller where such a location introduces additional or increased hazards to persons or property and conditions (a) and (b) are met.

- (a) The valve actuator motor assembly is marked with a warning label giving the location of the disconnecting means.
- (b) The provision for locking or adding a lock to the disconnecting means shall be installed on or at the switch or circuit breaker used as the disconnecting means and shall remain in place with or without the lock installed.

# 430.102 - Controller and disconnect location requirements



---

(B) Motor. A disconnecting means shall be provided for a motor in accordance with (B)(1) or (B)(2).

- (1) Separate Motor Disconnect. **A disconnecting means for the motor shall be located in sight from the motor location and the driven machinery location.**
- (2) Controller Disconnect. The controller disconnecting means required in accordance with 430.102(A) shall be permitted to serve as the disconnecting means for the motor if it is in sight from the motor location and the driven machinery location.



# 430.102 - Controller and disconnect location requirements

Exception to (1) and (2): The disconnecting means for the motor shall not be required under either condition (a) or condition (b), **provided the controller disconnecting means required in accordance with 430.102(A) is individually capable of being locked in the open position.** The provision for locking or adding a lock to the controller disconnecting means shall be installed on or at the switch or circuit breaker used as the **disconnecting means and shall remain in place with or without the lock installed.**

- (a) Where the location of the disconnecting means for the motor is impracticable or introduces additional or increased hazards to persons or property
- (b) In industrial installations, with written safety procedures, where conditions of maintenance and supervision ensure that only qualified persons service the equipment (if disconnect can be locked open)**

# 430.102 (B) Disconnect for Controller or Motor

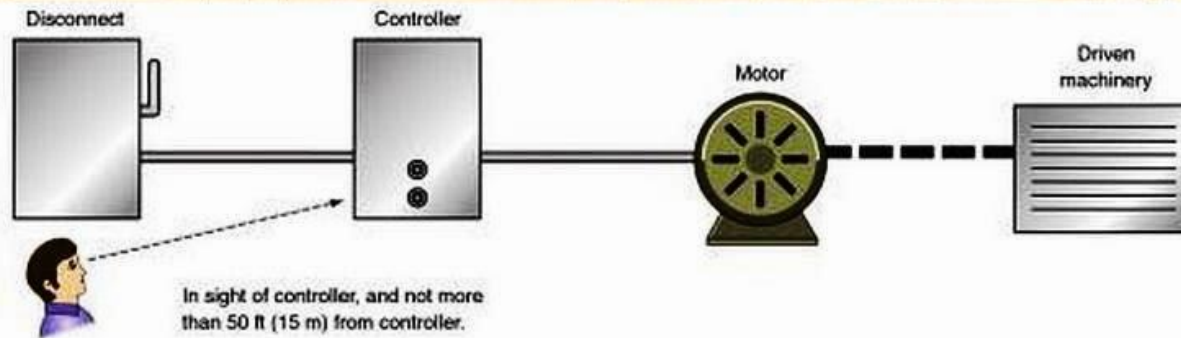

# 430.107 Readily Accessible



---

At least one of the disconnecting means shall be readily accessible.

# 430.110 – Combination Load Disconnect Sizing Requirements



---

1) Horsepower Rating. The rating of the disconnecting means shall be determined from the sum of all currents, including resistance loads, at the full-load condition and also at the locked-rotor condition. The combined full-load current and the combined locked-rotor current so obtained shall be considered as a single motor for the purpose of this requirement as follows.

The full-load current equivalent to the horsepower rating of each motor shall be selected from Table 430.247, Table 430.248, Table 430.249, or Table 430.250. These full-load currents shall be added to the rating in amperes of other loads to obtain an equivalent full-load current for the combined load.

# 430.110 – Combination Load Disconnect Sizing Requirements



- 
- The locked-rotor current equivalent to the horsepower rating of each motor shall be selected from Table 430.251(A) or 251(B).
  - The locked-rotor currents shall be added to the rating in amps of other loads to obtain an equivalent locked-rotor current for the combined load.
  - Where two or more motors or other loads cannot be started simultaneously, the largest sum of locked-rotor currents of a motor or group of motors that can be started simultaneously and the full-load currents of other concurrent loads shall be permitted to be used to determine the equivalent locked-rotor current for the simultaneous combined loads.



# 430.110 – Combination Load Disconnect Sizing Requirements

---

- (2) Ampere Rating. The ampere rating of the disconnecting means shall not be less than 115 percent of the sum of all currents at the full-load condition determined in accordance with 430.110(C)(1).

Exception: A listed nonfused motor-circuit switch having a horsepower rating equal to or greater than the equivalent horsepower of the combined loads, determined in accordance with 430.110(C)(1), shall be permitted to have an ampere rating less than 115 percent of the sum of all currents at the full-load condition.

- (3) Small Motors. For small motors not covered by Table 430.247, Table 430.248, Table 430.249, or Table 430.250, the locked-rotor current shall be assumed to be six times the full-load current.

# 430.112 Motors Served by Single Disconnecting Means.



Each motor shall be provided with an individual disconnecting means.

---

**Exception:** *A single disconnecting means shall be permitted to serve a group of motors under any one of the conditions of (a), (b), and (c). The single disconnecting means shall be rated in accordance with 430.110(C).*

- (a) Where a number of motors drive several parts of a single machine or piece of apparatus.
- (b) Where a group of motors is under the protection of one set of branch-circuit protective devices as permitted by 430.53(A).
- (c) Where a group of motors is in a single room within sight from the location of the disconnecting means.

## Adjustable speed drive requirements

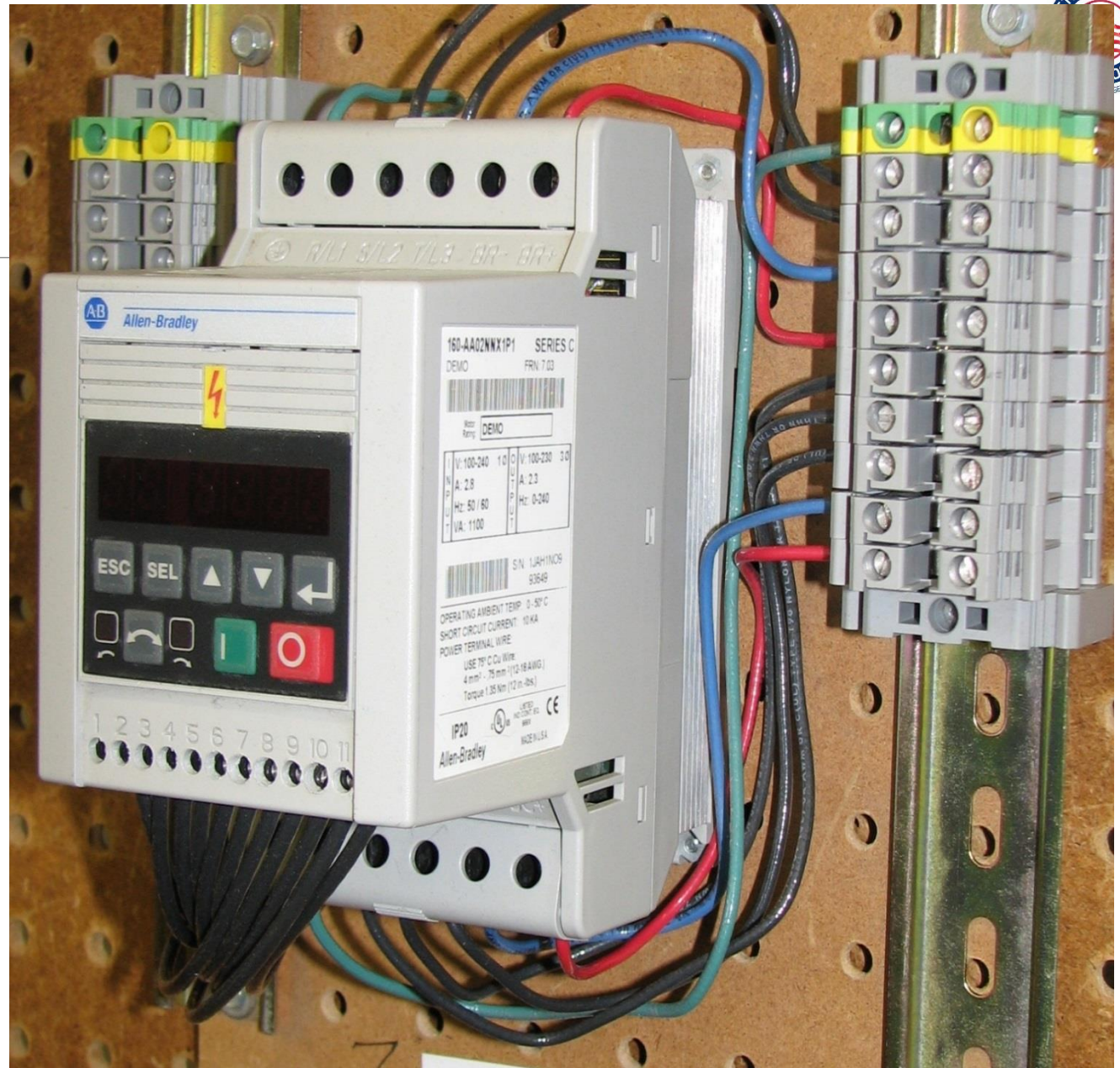

# 430.122 – Adjustable Speed Drive Requirements



---

## 430.122 Conductors — Minimum Size and Ampacity.

### (A) Branch/Feeder Circuit Conductors.

Circuit conductors supplying power conversion equipment included as part of an adjustable-speed drive system shall have an ampacity not **less than 125 percent of the rated input to the power conversion equipment.**

# 430.122 – Adjustable Speed Drive Requirements



## 380 - 480V AC – 3-Phase Input, 0 - 460V 3-Phase Output

22C-D6P0N103	2.2 (3.0)	6	340-528	6.3	7.5	10	140M-D8E-C10	100-C09	5098	105
22C-D010N103	4.0 (5.0)	10.5	340-528	10.9	13	20	140M-D8E-C16	100-C16	5098	171
22C-D012N103	5.5 (7.5)	12	340-528	11.9	14.2	20	140M-D8E-C16	100-C23	5098	200
22C-D017N103	7.5 (10)	17	340-528	15.3	18.4	25	140M-D8E-C20	100-C23	5098	267
22C-D022N103	11	22	340-528	19.2	23	30	140M-F8E-C32	100-C30	5098	329
22C-D030N103	15	27	340-528	25.8	31	40	140M-F8E-C32	100-C37	5098	435
22C-D038A103	18.5 (25)	38	340-528	33.3	40	50	140M-F8E-C45	100-C60	9086	606
22C-D045A103	22	45.5	340-528	39.1	47	60	-	100-C60	-	738
22C-D060A103	30	54	340-528	53.3	64	80	-	100-C85	-	664
22C-D072A103	37	72	340-528	60.7	73	100	-	100-C85	-	1019
22C-D088A103	45	88	340-528	74.9	90	125	-	100-D110	-	1245
22C-D105A103	55 (75)	105	340-528	89	107	150	-	100-D110	-	1487
22C-D142A103	75 (100)	128	340-528	124.8	150	200	-	100-D180	-	2043
22C-D170A103	90 (125)	170	340-528	142	170	250	-	100-D250	-	2617
22C-D208A103	110 (150)	208	340-528	167	200	250	-	-	-	-

75 HP

**Input Current 107 A**

**Variable Frequency Drives  
480 Volt Three-Phase Input  
0 – 460 Volt Three-Phase Output**

# 430.122 – Adjustable Speed Drive Requirements



## 430.122 Conductors — Minimum Size and Ampacity

---

75 hp previous page

$$107 \text{ A input current} \times 1.25 = 133.75$$

1/0 AWG

# 430.122 – Adjustable Speed Drive Requirements



- 
- (B) Bypass Device. For an adjustable speed drive system that utilizes a bypass device, the conductor ampacity shall not be less than required by 430.6. **The ampacity of circuit conductors supplying power conversion equipment** included as part of an adjustable-speed drive system that utilizes a bypass device **shall be the larger of either of the following:**
- (1) 125 percent of the rated input to the power conversion equipment
  - (2) 125 percent of the motor full-load current rating as determined by 430.6

# 430.124 Overload Protection



Overload protection of the motor shall be provided.

(A) Included in Power Conversion Equipment. **Where the power conversion equipment is marked to indicate that motor overload protection is included, additional overload protection shall not be required.**

# 430.124 Overload Protection.



---

## (B) Bypass Circuits.

For adjustable speed drive systems that utilize a bypass device to allow motor operation at rated full-load speed, motor overload protection as described in Article 430, Part III, shall be provided in the bypass circuit.

## (C) Multiple Motor Applications.

For multiple motor application, individual motor overload protection shall be provided in accordance with Article 430, Part III.

# 430.126 Motor Over temperature Protection.



## (A) General.

---

Adjustable speed drive systems shall protect against motor over temperature conditions where the motor is not rated to operate at the nameplate rated current over the speed range required by the application. This protection shall be provided in addition to the conductor protection required in 430.32. Protection shall be provided by one of the following means.

- (1) Motor thermal protector in accordance with 430.32
- (2) Adjustable speed drive system with load and speed-sensitive overload protection and thermal memory retention upon shutdown or power loss

Exception to (2): Thermal memory retention upon shutdown or power loss is not required for continuous duty loads.

- (3) Over-temperature protection relay utilizing thermal sensors embedded in the motor and meeting the requirements of 430.32(A)(2) or (B)(2)
- (4) Thermal sensor embedded in the motor whose communications are received and acted upon by an adjustable speed drive system

# 430.128 Disconnecting Means



---

The disconnecting means shall be permitted to be in the incoming line to the conversion equipment and shall have a rating not less than 115 percent of the rated input current of the conversion unit.



End of class material.

---

Remaining material for extra reference

# Short-Circuit Current Withstand Chart for Copper Cables with Thermoplastic Insulation

## Allowable Short-Circuit Currents for Insulated Copper Conductors\*

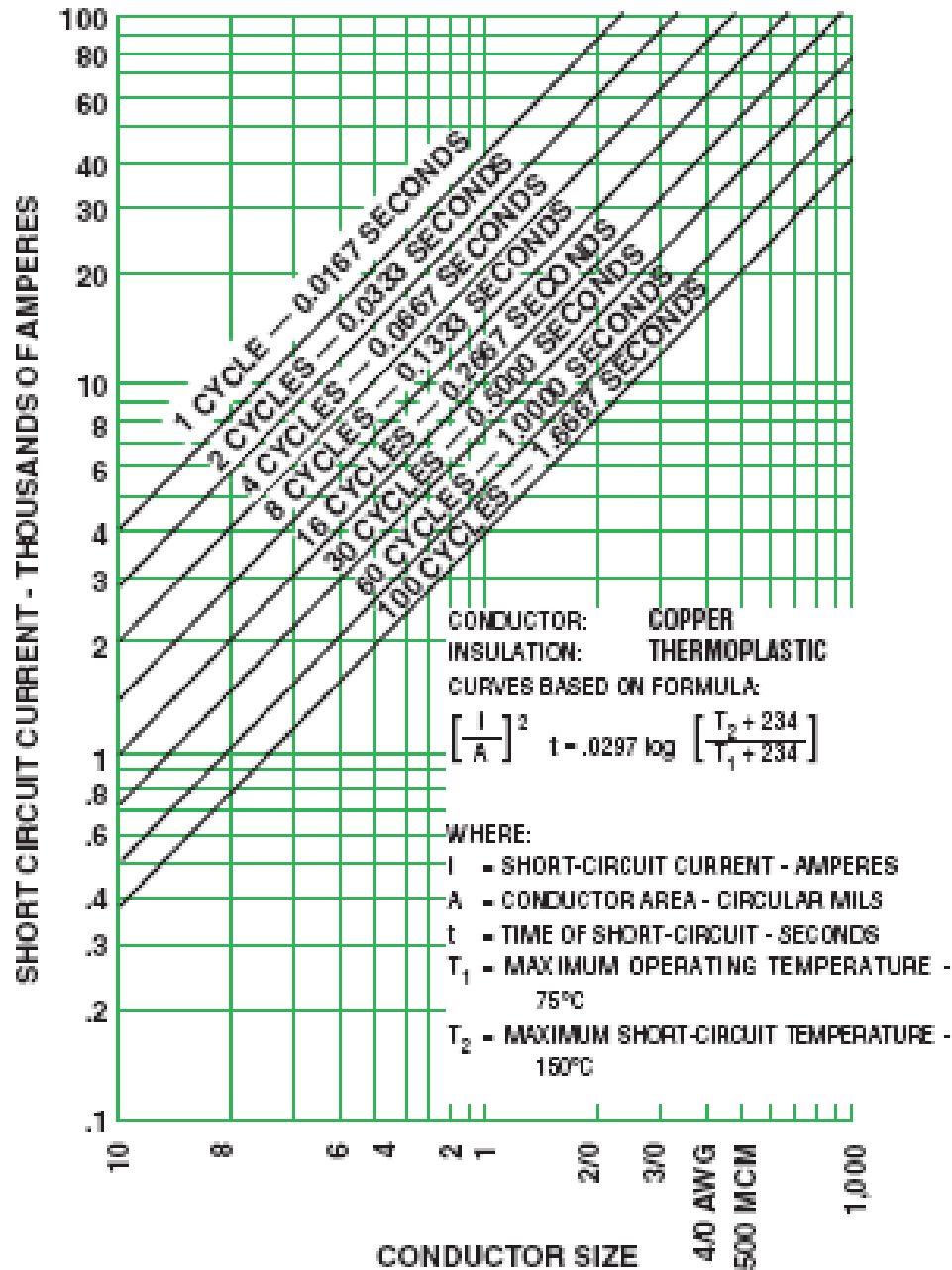

## Copper, 75° Thermoplastic Insulated Cable Damage Table (Based on 60 HZ)

Copper Wire Size 75°C Thermoplastic	Maximum Short-Circuit Withstand Current in Amperes					
	1/8	1/4	1/2	1	2	3
	Cycles*	Cycles*	Cycles*	Cycle	Cycles	Cycles
#14*	4,800	3,400	2,400	1,700	1,200	1,000
#12*	7,600	5,400	3,800	2,700	1,900	1,550
#10	12,000	8,500	6,020	4,300	3,000	2,450
#8	19,200	13,500	9,600	6,800	4,800	3,900
#6	30,400	21,500	16,200	10,800	7,600	6,200
#4	48,400	34,200	24,200	17,100	12,100	9,900

\* Extrapolated data.

**LOW-PEAK® YELLOW® Class L Time-Delay Fuses**  
**KRP-C\_8P**

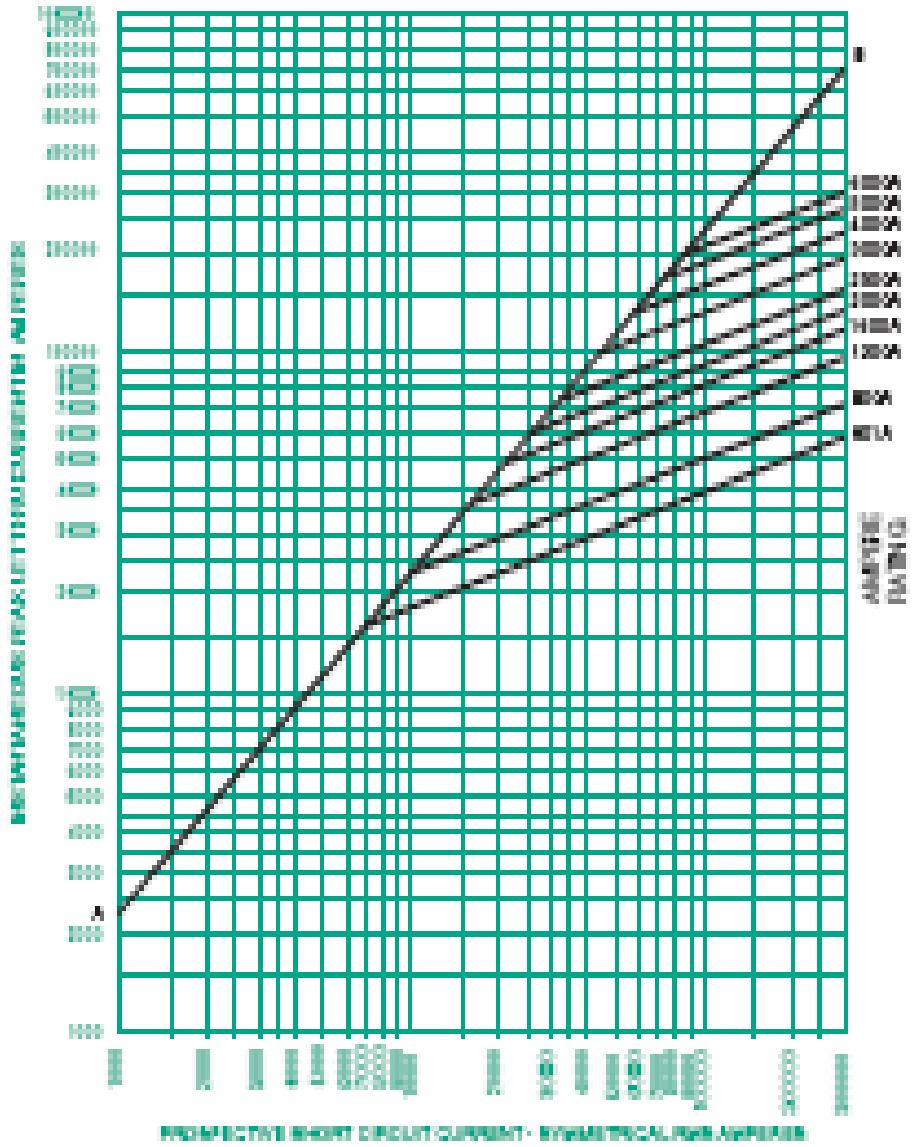

**KRP-C\_8P Fuse – RMS Let-Through Currents (kA)**

Prospective Short C.C.	Fuse Size									
	601	800	1200	1800	2500	3000	4000	5000	6000	8000
	kA	kA	kA	kA	kA	kA	kA	kA	kA	kA
5,000	5	5	5	5	5	5	5	5	5	5
10,000	8	10	10	10	10	10	10	10	10	10
15,000	9	12	15	15	15	15	15	15	15	15
20,000	10	13	17	20	20	20	20	20	20	20
25,000	11	14	19	22	25	25	25	25	25	25
30,000	11	14	20	24	27	30	30	30	30	30
35,000	12	15	21	25	29	35	35	35	35	35
40,000	13	18	22	26	30	35	40	40	40	40
50,000	14	17	23	28	32	37	50	50	50	50
60,000	15	18	25	30	34	40	49	60	60	60
70,000	15	19	26	32	36	42	52	62	70	70
80,000	16	20	27	33	38	44	54	65	76	80
90,000	17	21	29	34	39	45	56	67	79	90
100,000	17	22	30	36	41	47	58	70	81	100
150,000	20	25	34	41	47	54	67	80	93	104
200,000	22	27	37	45	51	59	73	87	102	114
250,000	24	29	40	49	55	64	79	94	110	123
300,000	25	31	43	52	59	68	84	100	117	130

Note: For  $I_{BUS}$  value at 300,000 amperes, consult Factory.



# Time — Current Characteristics at +40 °C (+104 °F)

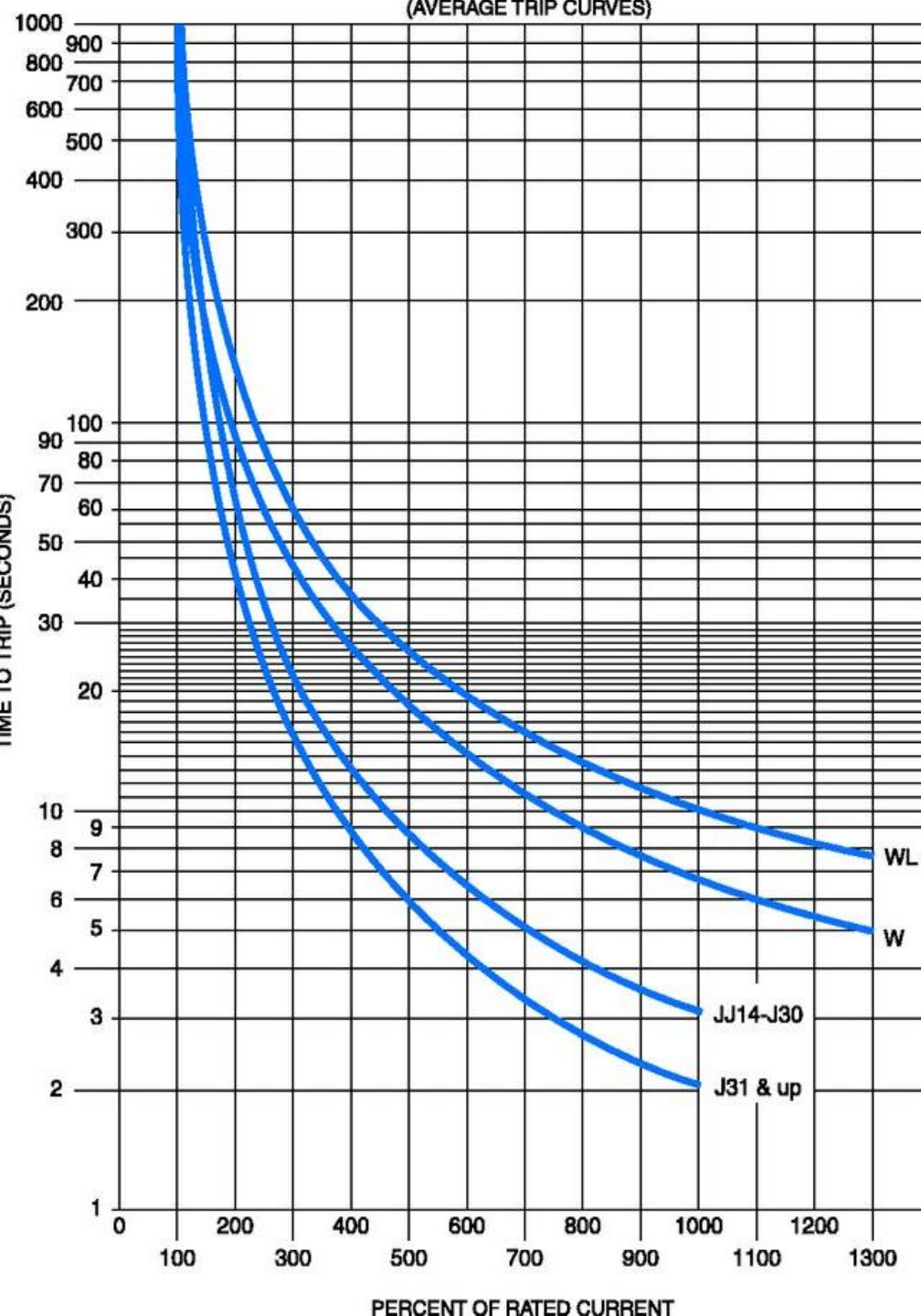

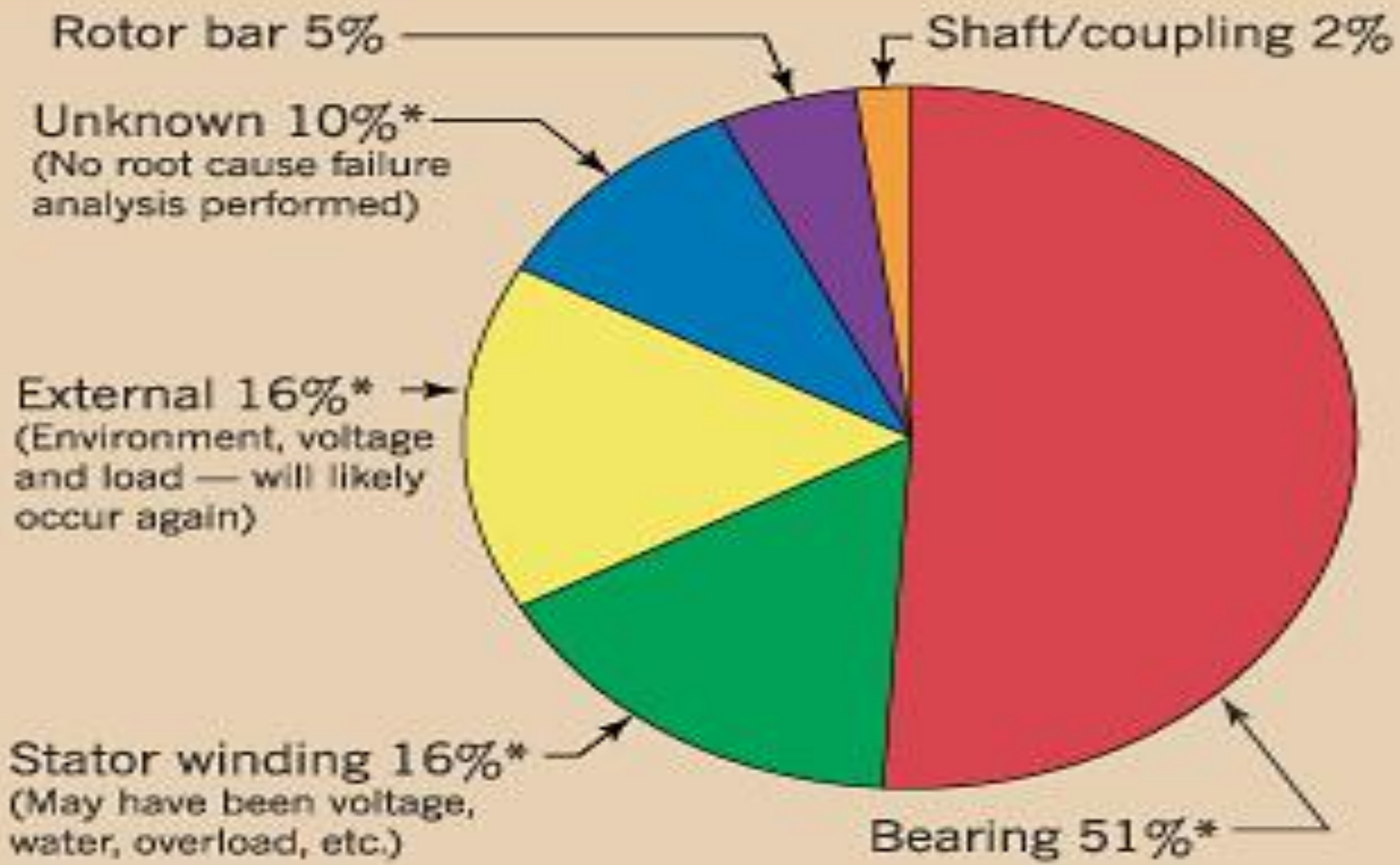

\* For each component shown, appropriate measures to prevent or predict the failure could greatly reduce three-quarters of motor failures.

Various forms of stress may affect the five major motor components.

<b>Motor Components and Stresses</b>					
<b>Type of stress</b>	<b>Bearings</b>	<b>Stator</b>	<b>Rotor</b>	<b>Shaft</b>	<b>Frame</b>
Thermal	X	X	X	X	X
Electric/dielectric	X	X	X		
Mechanical	X	X	X	X	X
Dynamic	X	X	X	X	X
Residual			X	X	X
Electromagnetic	X	X	X	X	
Environmental	X	X	X	X	X

Take the example below. The EGC must be protected from damage. It can withstand 4,300 amperes of current for 1 cycle. The 1 cycle opening time of the circuit breaker will cause damage to the #10 EGC. However, a current-limiting fuse will limit the cur-

rent to within the withstand rating of the EGC. An LPS-RK60SP will limit the line to ground current to approximately 3300 amperes, providing protection.

**VIOLATION**

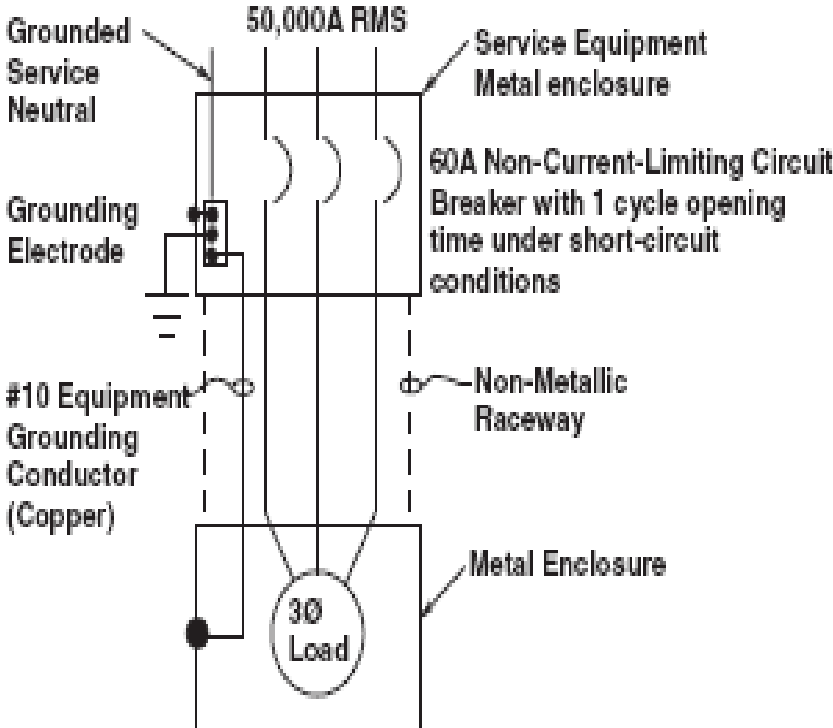

Would need to increase Equipment Grounding Conductor to 2/0, per ICEA Std. P-32-382.

**COMPLIANCE**

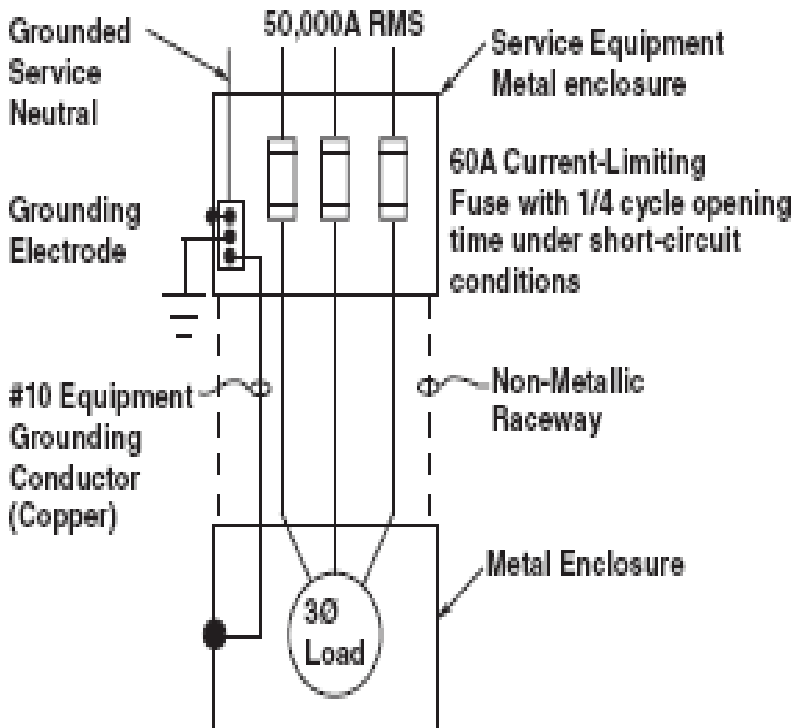

Conforms to Section 110-10 and 250-95.

Take the example below. The EGC must be protected from damage. It can withstand 4,300 amperes of current for 1 cycle. The 1 cycle opening time of the circuit breaker will cause damage to the #10 EGC. However, a current-limiting fuse will limit the cur-

rent to within the withstand rating of the EGC. An LPS-RK60SP will limit the line to ground current to approximately 3300 amperes, providing protection.

## VIOLATION

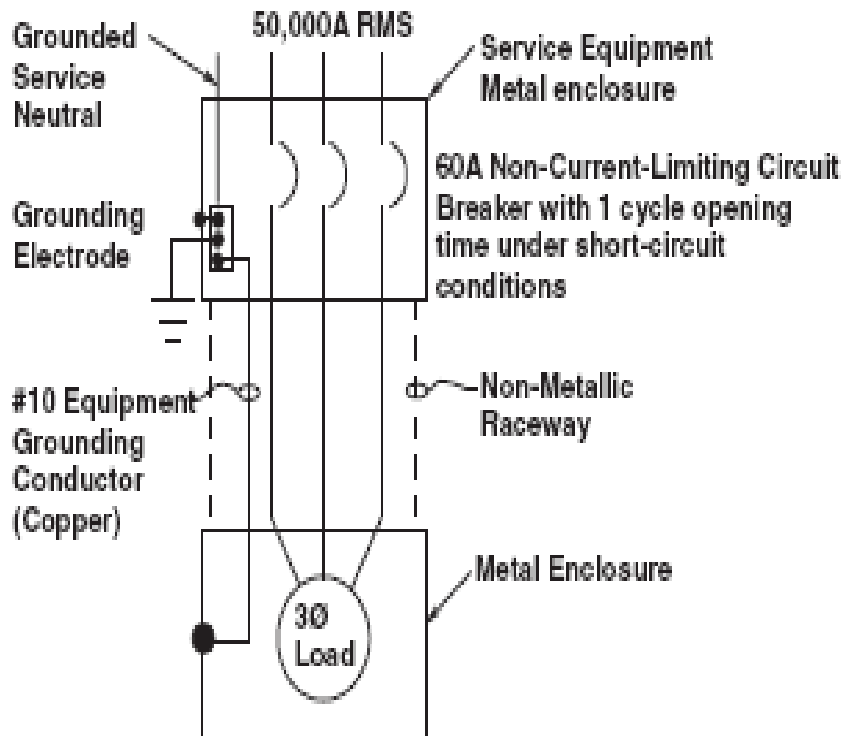

Would need to increase Equipment Grounding Conductor to 2/0, per ICEA Std. P-32-382.

## COMPLIANCE

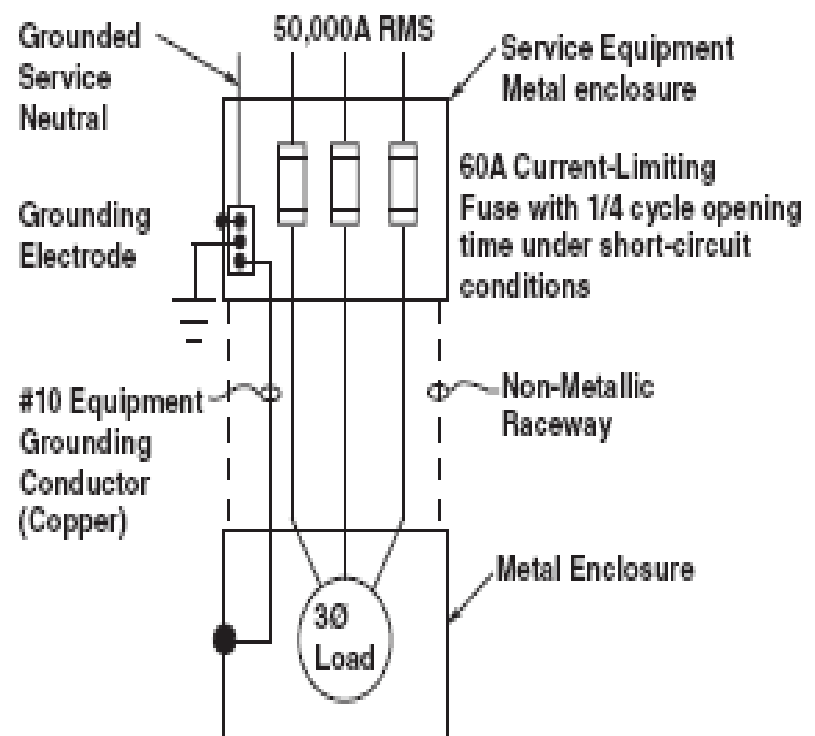

Conforms to Section 110-10 and 250-95.

Take the example below. The EGC must be protected from damage. It can withstand 4,300 amperes of current for 1 cycle. The 1 cycle opening time of the circuit breaker will cause damage to the #10 EGC. However, a current-limiting fuse will limit the cur-

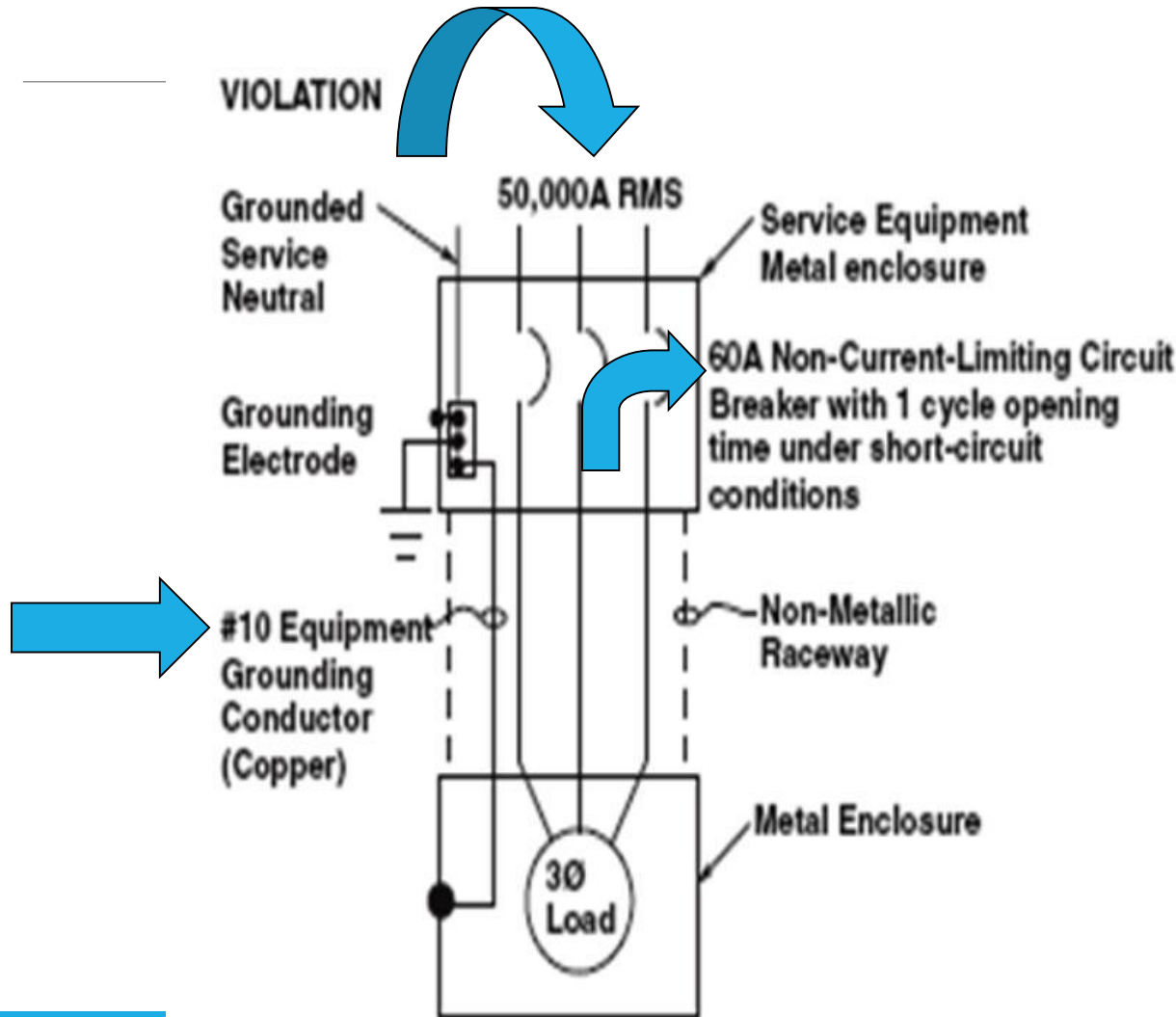

Would need to increase Equipment Grounding Conductor to 2/0, per ICEA Std. P-32-382.



---

[http://www.youtube.com/watch?v=7tEsJ-xAoEQ&feature=more\\_related](http://www.youtube.com/watch?v=7tEsJ-xAoEQ&feature=more_related)

How a motor is made



# DISCLAIMER

“Through the presentation of this course and/or these materials no representation actual or implied is made that the trainer or MEA/ETN is setting or enforcing specific standards or is providing peer review, certification, accreditation, or product testing”.

Use of NFPA Document 70-NEC®:

IACET requirements



# Learning outcome

The participant will use the information provided by the manufacturer with the motor and control equipment and size the equipment to be protected according to the National Electrical Code.

---

After completing the course you should be able to:

Define terminology associated with motor installations.

Determine and apply the appropriate motor ampacity ratings.

Interpret motor nameplate information.

Calculate locked-rotor current.

Determine the minimum size conductor for single motor and multiple motor installations.

Determine the maximum overload protection.



# Learning Outcomes

---

Determine maximum short-circuit and ground-fault protection for a motor branch circuit and feeder.

Design a code-compliant control circuit.

Select a suitable controller.

Provide a disconnecting means for the controller, motor and driven machinery.

Determine and apply the requirements for an Adjustable-Speed Drive System.

# Introduction & 430.1

General, 430.1 through 430.18  
 Motor Circuit Conductors, 430.21 through 430.29  
 Motor and Branch-Circuit Overload Protection, 430.31 through 430.44  
 Motor Branch-Circuit Short-Circuit and Ground-Fault Protection, 430.51 through 430.58  
 Motor Feeder Short-Circuit and Ground-Fault Protection, 430.61 through 430.63  
 Motor Control Circuits, 430.71 through 430.75  
 Motor Controllers, 430.81 through 430.90  
 Motor Control Centers, 430.92 through 430.98  
 Disconnecting Means, 430.101 through 430.113  
 Adjustable-Speed Drive Systems, 430.120 through 430.131  
 Over 1000 Volts, Nominal, 430.221 through 430.227  
 Protection of Live Parts—All Voltages, 430.231 through 430.233  
 Grounding—All Voltages, 430.241 through 430.245  
 Tables, Tables 430.247 through 430.251(B)

Part I  
 Part II  
 Part III  
 Part IV  
 Part V  
 Part VI  
 Part VII  
 Part VIII  
 Part IX  
 Part X  
 Part XI  
 Part XII  
 Part XIII  
 Part XIV

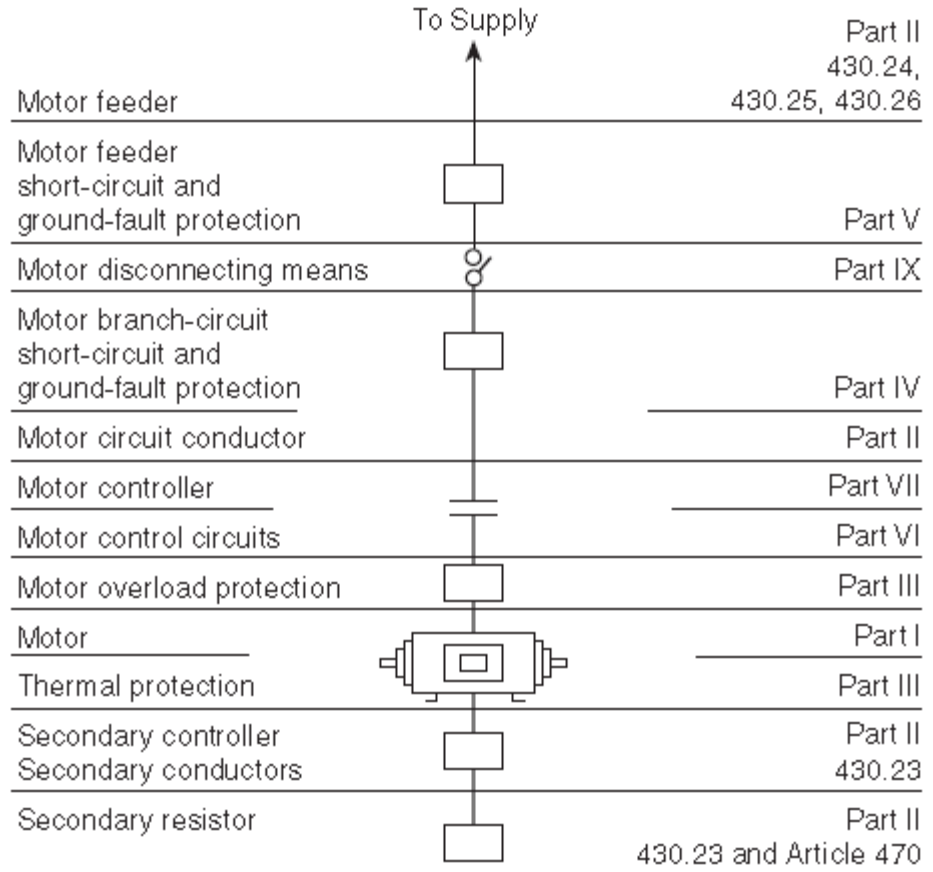

---

## **National Electrical Code**

### **NEPA 70**

Usual motor application nameplate requirements are in 430.7



# Motor Information Shall Contain:

- 
- Name of Manufacturer

# Effects of motor supply voltage variations.



## Voltage – rated/tested value

The circuit voltage for induction motors should generally be within **±10 percent** of the motor nameplate rating.

# Effects of motor supply voltage variations



---

Voltage differences between phase conductors of three-phase motor circuits **cause unequal phase currents which can exceed the nameplate rating**. Under such conditions, **torque and full-load speed will be slightly decreased and operating temperature will increase**. The percentage of full-load current imbalance will be 6 to 10 times the percentage of the voltage imbalance. *(For example, a 1 percent difference in voltage between phase conductors of a 480-volt circuit (4.8 volts) can produce a 6 to 10 percent difference in phase currents.)*

**Three percent voltage imbalance decreases the horsepower a motor can deliver without overheating to about 90 percent of its nameplate rating.**

# Effects of motor supply voltage variations

Overvoltage and undervoltage have the effects of:

Characteristic	Voltage	
	110%	90%
Starting torque	Increase 21%	Decrease 19%
Full-load torque	Increase 21%	Decrease 19%
Full-load speed	Increase 1%	Decrease 1.5%
Full-load efficiency	Increase 0.05-0.1%	Decrease 0.2%
F.L. power factor	Decrease 0.3%	Increase 0.1%
Starting current	Increase 10-12%	Decrease 10-12%
Full-load current	Decrease 7%	Increase 11%
Temperature rise	Decrease 3-4°C	Increase 6 -7°C
Maximum overload	Increase 21%	Decrease 19%

# Motor Information Shall Contain



- 
- Amperes – operating at rated voltage and HP at full mechanical load (*not necessarily code book value*) *Full load for each speed- except for shaded pole and Perm split cap motors*

# Motor Information Shall Contain



---

Rated frequency - designed to operate at rated values HP and speeds at rated frequency and number of phases



# Motor Information Shall Contain:

---

- Horsepower – energy output at the motor shaft at 100% of mechanical load



# Motor Information Shall Contain

---

- RPM – at rated voltage, HP, and at full load

# Motor Information Shall Contain



- 
- Insulation System Class and ambient temperature, or rated temperature rise



# Insulation Class Letter

---

CLASS A - 105°C

CLASS B - 130°C

CLASS F - 155°C

CLASS H - 180°C many modern motors are upgrading to this higher temp insulation

Life expectancy of motor insulation at 20,000 hours

# Insulation Class

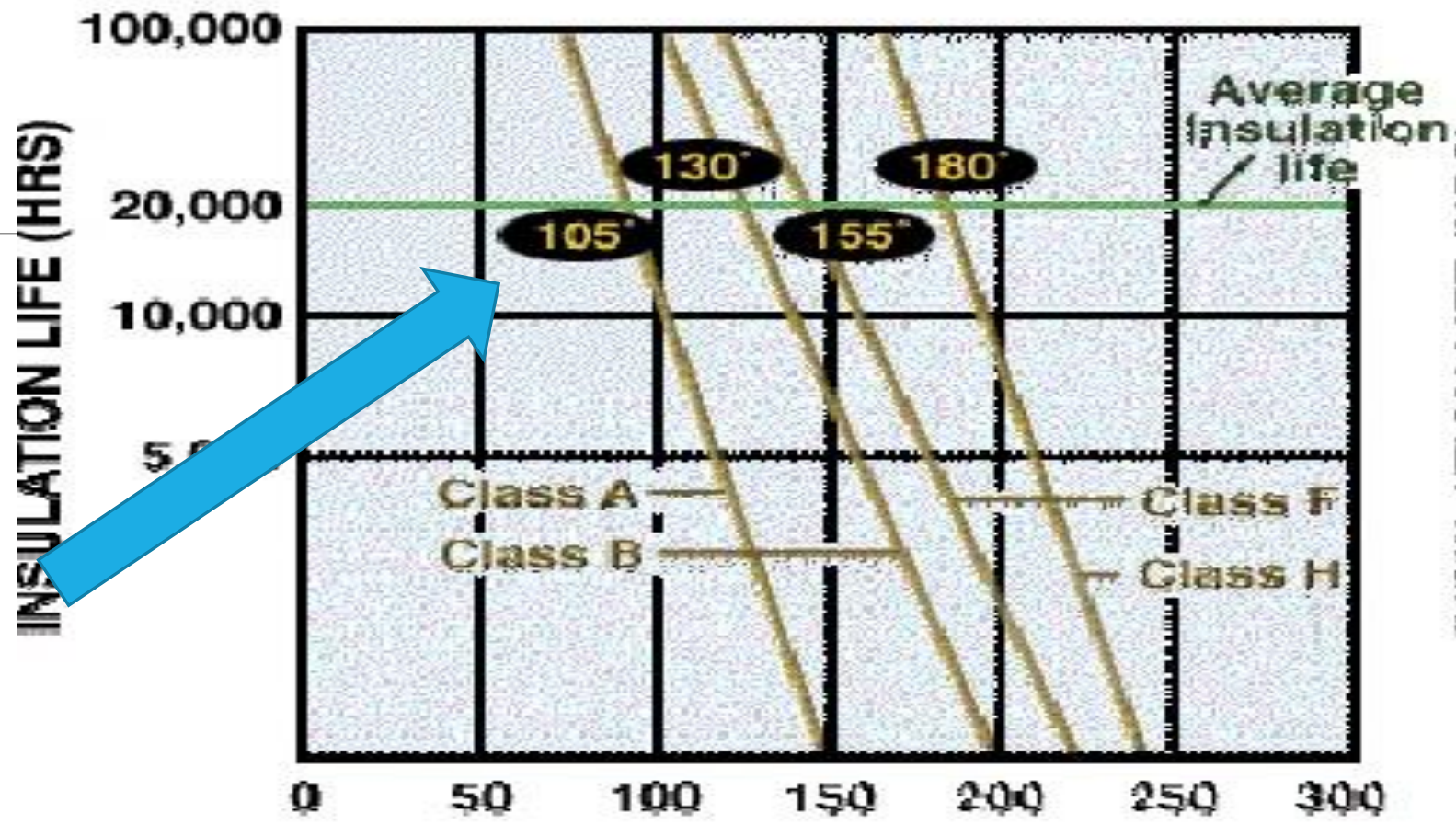

WINDING TEMPERATURE IN °C  
 HOUR LIFE TEMPERATURE CLASS 20,000 HOUR LIFE TEMPERATURE

105°C	A
130°C	B
155°C	F
180°C	H

# Temp Rise vs. Safe Insulation Temperature



Temperature Tolerance Class	Maximum Operation Temperature Allowed		Allowable Temperature Rise at full load 1.0 service factor motor <sup>1)</sup>	Allowable Temperature Rise 1.15 service factor motor <sup>1)</sup>
	°C	°F	°C	°C
A	105	221	60	70
B	130	266	80	90
F	155	311	105	115
H	180	356	125	-



# Motor Information Shall Contain

---

Time rating: ratings at 5 min, 15, 30, 60, or Continuous



# Motor Information Shall Contain

---

Service Factor – a multiplier (factor) applied to the rated HP indicating the HP over the nameplate –  
the motor may operate for short periods

# Motor Information Shall Contain



- 
- Code letter – locked rotor kVA – starting current

# Table 430.7(B) Locked-Rotor Indicating Code Letters

Code Letter	Kilovolt-Amperes per Horsepower with Locked Rotor
• A	0–3.14
• B	3.15–3.54
• C	3.55–3.99
• D	4.0–4.49
• E	4.5–4.99
• F	5.0–5.59
• G	5.6–6.29
• H	6.3–7.09
• J	7.1–7.99
• K	8.0–8.99
• L	9.0–9.99
• M	10.0–11.19
• N	11.2–12.49
• P	12.5–13.99
• R	14.0–15.99
• S	16.0–17.99
• T	18.0–19.99
• U	20.0–22.39
• V	22.4 and up



# Motor Information Shall Contain

- **Design Letter – operating characteristics of the motor**



# Design “A” Motors

---

Not commonly specified but specialized motors used on injection molding applications have characteristics similar to Design A.

The most important characteristic of **Design A is the high pullout torque.**

# Design “B” Motor



---

**Is the standard industrial duty motor which has reasonable starting torque with moderate starting current and good overall performance for most industrial applications.**

# Design “C” Motor

---



Is used for hard to start loads and is specifically **designed to have high starting torque.**



# Design “D” Motor

---

Are suited for low speed, punch press applications and hoist and elevator applications. The **efficiency of Design D motors at full load is rather poor and are normally used on applications where the torque characteristics are of primary importance.**

# Motor Design Speed / Torque Curves

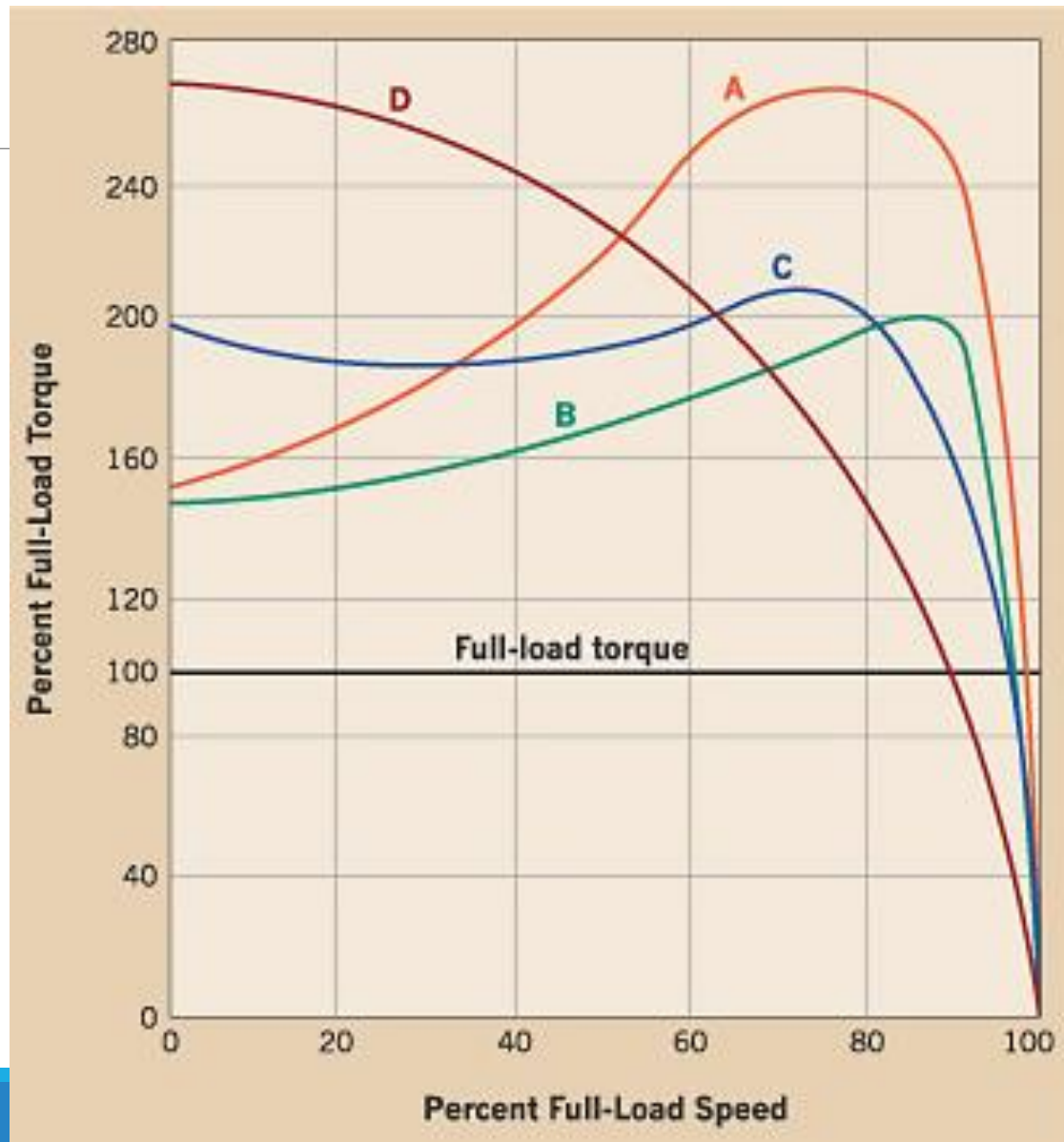



---

# General Single Motor Installation

# Motor Nameplate Information for example calculations



---

**30HP, 460V, 38A, 3 $\emptyset$ , S.F. 1.15,  
40°C AMB., Code G, Design B, Cont. Duty, 1725 RPM, 60Hz, Ins. Class B.**

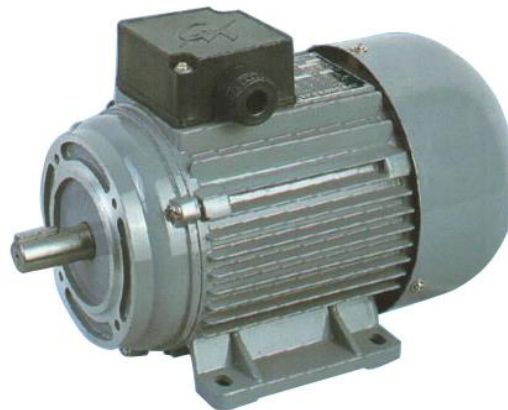



# Parameters for examples :

---

Continuous-Duty Motors

75°C Copper Conductors

Normal Starting and Load Conditions

RPM ratings at or above 1150 (1200 Synchronous)

Service Factor 1.0 or 1.15

# Locked-Rotor Current



---

The current, in amperes, a motor draws from the source when energized at its rated voltage, but the rotor is not turning.

A code letter indicating the kVA per horsepower is found in NEC 430.7(B)

$$I_{LRC} = \frac{kVA \text{ per HP} \times HP}{E \times 1.732}$$

# Table 430.7(B) Locked-Rotor Indicating Code Letters



Code Letter	Kilovolt-Amperes per Horsepower with Locked Rotor
A.....	0 – 3.14
B.....	3.15 – 3.54
C.....	3.55–3.99
D.....	4.0 – 4.49
E.....	4.5 – 4.99
F.....	5.0 – 5.59
<b>G.....</b>	<b>5.6 – 6.29</b>
H.....	6.3 – 7.09
J.....	7.1 – 7.99
K.....	8.0 – 8.99
L.....	9.0 – 9.99
M.....	10.0 – 11.19
N.....	11.2 – 12.49
P.....	12.5 – 13.99



# Code Letter – Table 430.7(B)

---

Locked Rotor kVA per Horsepower – same as starting current

Code G 5.60 – 6.29,

$$6.29 \times 30 \text{ HP} = \underline{119.7 \text{ kVA}} = 236.8 \text{ amps}$$
$$(460 \times 1.732)$$

Maximum starting current is **236.8 amps**

# Worksheet

## Multi-motor installation using 3 phase motors

---

**Motors are: Continuous duty, Design B motors**

**75 HP**

**60 HP**

**50 HP**

**40 HP**



# Worksheet Example: Calculate LRC

Motor Branch Circuit Calculations											
HP	Motor	Volts	PH	Name-plate Current Rating	Code Letter	Service Factor	Maximum Locked-Rotor Current	Minimum Size THWN Conductor	AB 193-E1 Plus Overload Maximum Dial Setting	Maximum SC & GF Dual-Element Time-Delay Fuse	Minimum Controller Size
75	M-1	460	3	92	H	1.15					
60	M-2	460	3	68	G	1.15					
50	M-3	460	3	58	G	1.15					
40	M-4	460	3	46	H	1.00					
Motor Feeder Calculations											
Minimum Circuit Ampacity				Minimum Size THWN Conductor				Maximum SC & GF Dual-Element, Time-Delay, Fuse			



# Worksheet Answers: LRC

Motor Branch Circuit Calculations											
HP	Motor	Volts	PH	Name-plate Current Rating	Code Letter	Service Factor	Maximum Locked-Rotor Current	Minimum Size THWN Conductor	AB 193-E1 Plus Overload Maximum Dial Setting	Maximum SC & GF Dual-Element Time-Delay Fuse	Minimum Controller Size
75	M-1	460	3	92	H	1.15	667				
60	M-2	460	3	68	G	1.15	474				
50	M-3	460	3	58	G	1.15	395				
40	M-4	460	3	46	H	1.00	356				
Motor Feeder Calculations											
Minimum Circuit Ampacity				Minimum Size THWN Conductor				Maximum SC & GF Dual-Element, Time-Delay, Fuse			

# 430.6 – Determine the values to be used to size the motor Equipment



- 
- (1) The values given in Tables 430.247, 248, 249, and 250 shall be used to determine the ampacity of:
- conductors or
  - ampere ratings of switches,
  - branch-circuit short-circuit and ground-fault protection,
  - **instead of the actual current marked on the motor nameplate.**



# 430.6 – Determine the values to be used to size the motor hardware

Where a motor is marked in amperes, not horsepower, the HP rating shall be assumed to be corresponding to the value in Tables 430.247, .248, .249, and .250, **interpolated if necessary.**

Motors built for low speed or high torque, or multispeed motors - having higher full-load currents than the table, the nameplate current ratings shall be used.

See exceptions 1-3

**Table A: Dimensions and Frame Comparisons, IEC and NEMA**

		IEC and NEMA dimensions in mm						KW and HP Ratings 3 Phase TEFC Motors		
IEC NEMA	(H) D	(A) E	(B) F	(K) H	(D) U	(C) BA	(E) N-W	2 Pole	4 Pole	6 Pole
56 NA	56 ---	45 ---	35.5 ---	5.8 ---	9 ---	36 ---	20 --	---	---	---
63 42	63 66.7	50 44.5	40 21.4	7 7.1	11 9.5	40 52.4	23 28.6	.25 KW 1/3 HP	.18KW 1/4 HP	---
71 48	71 76.2	56 54	45 34.9	7 8.7	14 12.7	45 63.5	30 38.1	0.55 3/4	0.37 1/2	---
80 56	80 88.9	62.5 61.9	50 38.1	10 8.7	19 15.9	50 69.9	40 47.6	1.1 1-1/2	0.75 1	0.55 3/4
90S 143T	90 88.9	70 69.8	50 50.8	10 8.7	24 22.2	56 57.2	50 57.2	1.5 2	1.1 1-1/2	0.75 1
90L 145T	90 88.9	70 69.8	62.5 63.5	10 8.7	24 22.2	56 57.2	50 57.2	2.2 3	1.5 2	1.1 1-1/2
100L NA	100 ---	80 ---	70 ---	12 ---	28 ---	63 ---	60 ---	3 4	2.2 3	1.5 2
112S 182T	112 114.3	95 95.2	57 57.2	12 10.7	28 28	70 70	60 69.9	3.7 5	2.2 3	1.5 2
112M 184T	112 114.3	95 95.2	70 68.2	12 10.7	28 28	70 70	60 69.9	3.7 5	4 5.4	2.2 ---
132S 213T	132 133.4	108 108	70 69.8	12 10.7	38 34.9	89 89	80 85.7	7.5 10	5.5 7-1/2	3 ---
132M 215T	132 133.4	108 108	89 88.8	12 10.7	38 34.9	89 89	80 85.7	---	7.5 10	5.5 7-1/2
160M* 254T	160 158.8	127 127	105 104.8	15 13.5	42 41.3	108 108	110 101.6	15 20	11 15	7.5 10
160L* 256T	160 158.8	127 127	127 127	15 13.5	42 41.3	108 108	110 101.6	18.5 25	15 20	11 15

# Motor nameplate for kW rating





# 430.6 – Determine the values to be used to size the motor hardware

## (2) Nameplate Values.

Separate **motor overload protection shall be based on the motor nameplate current rating.**

<b>SIEMENS</b>									
PE•21 PLUS™					PREMIUM EFFICIENCY				
ORD.NO.	1LA02864SE41				E. NO.				
TYPE	RGZESD				FRAME	286T			
H. P.	30.00				SERVICE FACTOR	1.15		3 PH	
AMPS	34.9				VOLTS	460			
R.P.M.	1765				HERTZ	60			
DUTY	CONT				40 °C AMB.			DATE CODE	
CLASS INSUL	F	NEMA DESIGN	B	K.V.A. CODE	G	NEMA. NOM. EFF.	93.6		
SH. END BRG.	50BC03JPP3				OPP. END BRG.	50BC03JPP3			
<b>MILL AND CHEMICAL DUTY QUALITY INDUCTION MOTOR</b>									
Siemens Energy & Automation, Inc. Little Rock, AR							MADE IN U.S.A.		

51-770-642





# 430.6 – *Table Value for sample motor*

---

## Table 430.250

30 hp, 460 V motor - 3Ø:

**40 amps**

**2017 NEC pg. 322**

# Minimum Circuit Ampacity

A calculation necessary to select a conductor size by first applying the appropriate National Electrical Code requirements to determine the ampere rating of the expected load.

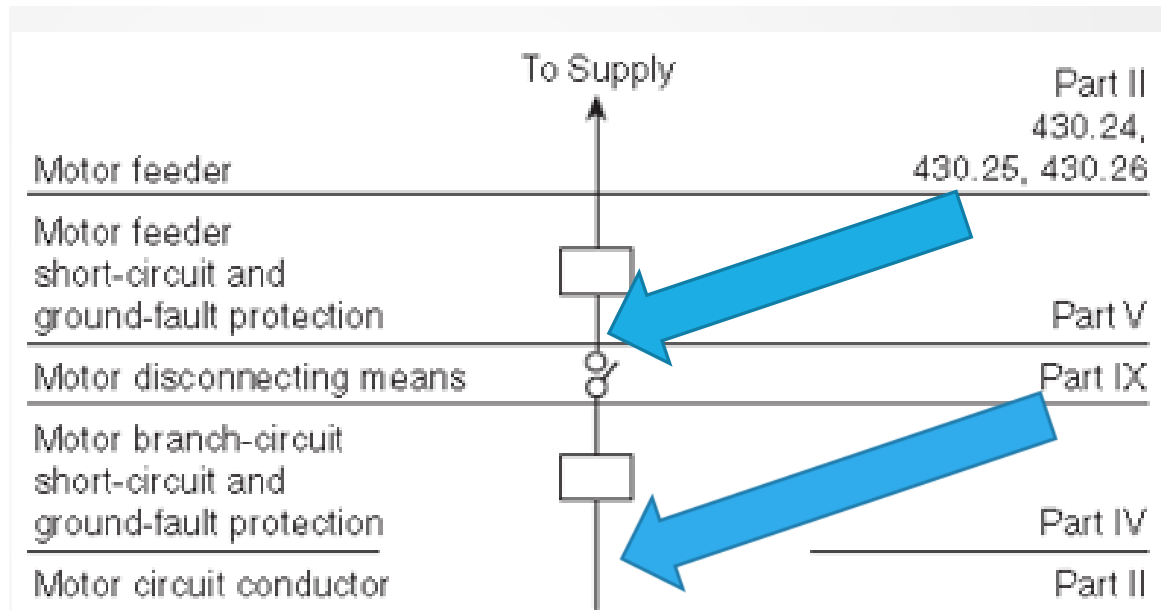

# Part II – 430.21/22 – Size the conductor



---

.22 (A) General. Conductors that supply a single motor in a continuous duty application shall have an ampacity of not less than **125 percent** of the motor's full-load current rating as determined by 430.6(A)(1) or (A) –(G)

30 hp, 480V, 38A, 3Ø, S.F. 1.15, 40°C  
AMB., Code C, Design B, cont. duty  
1725RPM, 60Hz, Ins. Class B.

Sample motor:

$$40 \times 1.25 = 50 \text{ amps}$$

8 AWG @ 75° C

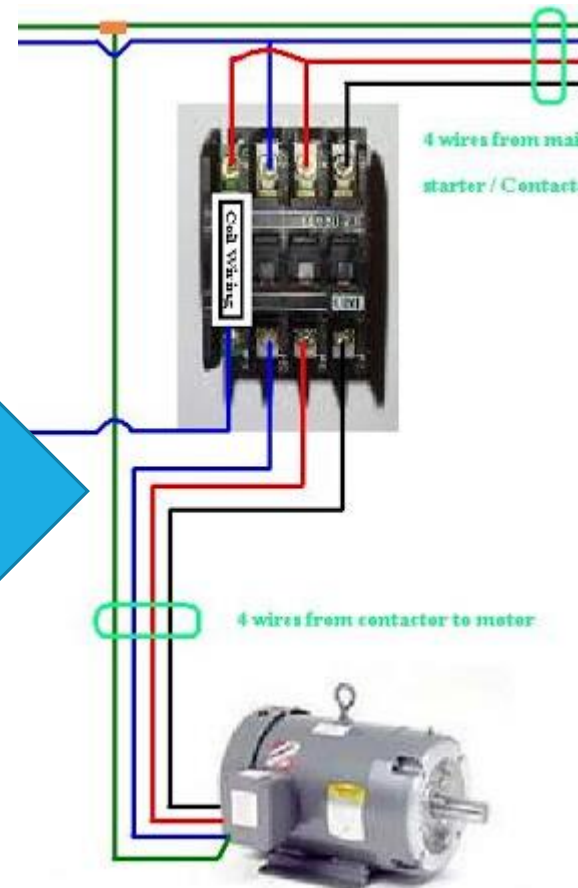

# Worksheet Example: Size wire for branch circuit



## Motor Branch Circuit Calculations

HP	Motor	Volts	PH	Name-plate Current Rating	Code Letter	Service Factor	Maximum Locked-Rotor Current	Minimum Size THWN Conductor	AB 193-E1 Plus Overload Maximum Dial Setting	Maximum SC & GF Dual-Element Time-Delay Fuse	Minimum Controller Size
75	M-1	460	3	92	H	1.15	667				
60	M-2	460	3	68	G	1.15	474				
50	M-3	460	3	58	G	1.15	395				
40	M-4	460	3	46	H	1.00	356				

## Motor Feeder Calculations

Minimum Circuit Ampacity	Minimum Size THWN Conductor	Maximum SC & GF Dual-Element, Time-Delay, Fuse



# Worksheet Answers

## Motor Branch Circuit Calculations

HP	Motor	Volts	PH	Name-plate Current Rating	Code Letter	Service Factor	Maximum Locked-Rotor Current	Minimum Size THWN Conductor	AB 193-E1 Plus Overload Maximum Dial Setting	Maximum SC & GF Dual-Element Time-Delay Fuse	Minimum Controller Size
75	M-1	460	3	92	H	1.15	667	1 AWG			
60	M-2	460	3	68	G	1.15	474	3 AWG			
50	M-3	460	3	58	G	1.15	395	4 AWG			
40	M-4	460	3	46	H	1.00	356	6 AWG			

## Motor Feeder Calculations

Minimum Circuit Ampacity	Minimum Size THWN Conductor	Maximum SC & GF Dual-Element, Time-Delay, Fuse



---

# Motors Installed on a Feeder



# Definition: Feeder (NEC)

---

All circuit conductors between the service equipment, the source of a separately derived system, or other power supply source and the final branch-circuit overcurrent device.

# 430.24 Several Motors or a Motor(s) and Other Load(s).



---

Conductors supplying several motors, or a motor(s) and other load(s), shall have an ampacity **not less than 125 percent of the full-load current rating of the highest rated motor** plus the sum of the full-load current ratings of all the other motors in the group, as determined by 430.6(A), plus the ampacity required for the other loads.



# Worksheet Example to size feeder

## Motor Branch Circuit Calculations

HP	Motor	Volts	PH	Name-plate Current Rating	Code Letter	Service Factor	Maximum Locked-Rotor Current	Minimum Size THWN Conductor	AB 193-E1 Plus Overload Maximum Dial Setting	Maximum SC & GF Dual-Element Time-Delay Fuse	Minimum Controller Size
75	M-1	460	3	92	H	1.15	667	1 AWG			
60	M-2	460	3	68	G	1.15	474	3 AWG			
50	M-3	460	3	58	G	1.15	395	4 AWG			
40	M-4	460	3	46	H	1.00	356	6 AWG			

## Motor Feeder Calculations

Minimum Circuit Ampacity	Minimum Size THWN Conductor	Maximum SC & GF Dual-Element, Time-Delay, Fuse



# Worksheet Answers: Feeder

## Motor Branch Circuit Calculations

HP	Motor	Volts	PH	Name-plate Current Rating	Code Letter	Service Factor	Maximum Locked-Rotor Current	Minimum Size THWN Conductor	AB 193-E1 Plus Overload Maximum Dial Setting	Maximum SC & GF Dual-Element Time-Delay Fuse	Minimum Controller Size
75	M-1	460	3	92	H	1.15	667	1 AWG			
60	M-2	460	3	68	G	1.15	474	3 AWG			
50	M-3	460	3	58	G	1.15	395	4 AWG			
40	M-4	460	3	46	H	1.00	356	6 AWG			

## Motor Feeder Calculations

Minimum Circuit Ampacity	Minimum Size THWN Conductor	Maximum SC & GF Dual-Element, Time-Delay, Fuse
314	400 kcmil	

# 430.32

---

## Sizing the Overloads (Heaters)

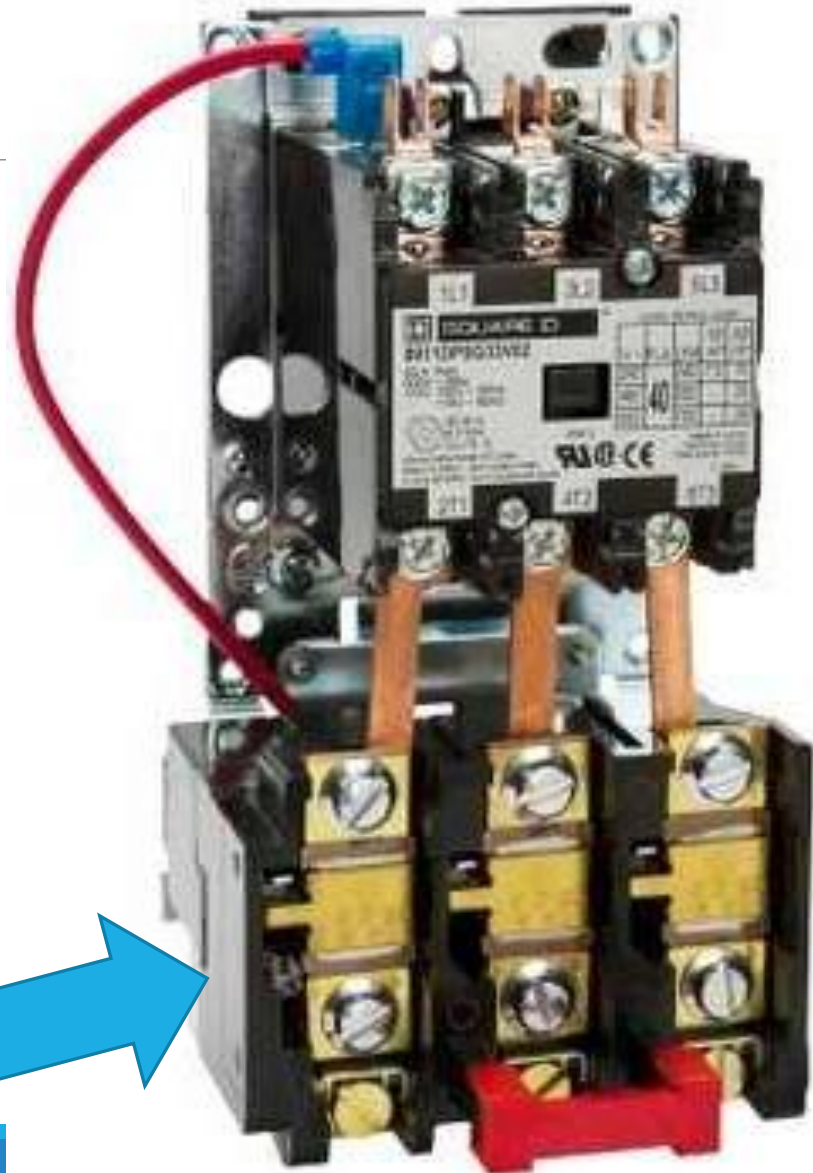



# Definition: Overload (NEC)

---

Operation of equipment in excess of normal, full-load rating, or of a conductor in excess of rated ampacity that, when it persists for a sufficient length of time, would cause damage or dangerous overheating.

A fault, such as a short circuit or ground fault, is not an overload.



# Part III – 430.31.32 – Sizing the Overloads

---

## (A) More than 1 Horsepower.

Each motor used in a continuous duty application and rated more than 1 hp shall be protected against overload by one of the means in 430.32(A)(1) - (A)(4).

# 430.32 – Sizing the Overloads

---



- (1) Separate Overload Device. A separate overload device that is responsive to motor current. This device shall be **selected to trip** or shall be rated at no more than the following percent of the motor **nameplate** full-load current rating:
- Motors with a marked service factor 1.15 or greater - **125%**
  - Motors with a marked temperature rise 40°C or less - **125%**
  - All other motors - **115%**

# 430.32 – Sizing the Overloads: Example motor

---



38A nameplate  $\times 1.25 = 47.5$  amps

the max *Trip Current Rating* of the

OL device



# Thermal overload classification

(NEMA) designates an overload relay by a class number indicating the maximum time in seconds at which it will trip when carrying a current equal to 600 percent of its current rating.

A **Class 10** overload relay **will trip in 10 seconds or less** at a current equal to **600 percent** of its rating.

A **Class 20** overload relay **will trip in 20 seconds or less** at a current equal to **600 percent** of its rating.

A **Class 30** overload relay will **trip in 30 seconds** or less at a current equal to **600 percent** of its rating.

A **class 10A** is used for IEC at 7.2 times rating trips at 2-10 seconds



# NEC overload selection

The following is for motors rated for Continuous Duty:

For motors with marked service factor of not less than 1.15, or motors with a marked temperature rise not over  $+40^{\circ}\text{C}$  ( $+104^{\circ}\text{F}$ ), apply application rules 1 through 3.

Apply application rules 2 and 3 when the temperature rise does not exceed  $+10^{\circ}\text{C}$  ( $+18^{\circ}\text{F}$ ). When the temperature difference is greater, see below.



# Practical overload selection

For motors with **Marked Service Factor of *less than 1.15***, select the “Heater Type Number” **one rating smaller than** determined by the rules in paragraphs 1, 2 and 3.



# Practical overload selection

1. **The Same Temperature at the Controller and the Motor** Select the “Heater Type Number” with the listed “Full Load Amperes” nearest the full load value shown on the motor nameplate.
2. **Higher Temperature at the Controller than at the Motor** If the full load current value shown on the motor nameplate is between the listed “Full Load Amperes”, select the “Heater Type Number” with the higher value.
3. **Lower Temperature at the Controller than at the Motor** If the full load current value shown on the motor nameplate is between the listed “Full Load Amperes”, select the “Heater Type Number” with the lower value.

## Standard **Trip-Class 20** Heater Packs

Part Number

(Three heater packs) Price Max.

Amps

Motor Full Load Ampere Rating Dial Position

A B C D

**H2001B-3** <---> 32 .254 .306 .359 .411

**H2002B-3** <---> 32 .375 .452 .530 .607

**H2003B-3** <---> 32 .560 .676 .791 .907

**H2004B-3** <---> 32 .814 .983 1.15 1.32

**H2005B-3** <---> 32 1.20 1.45 1.71 1.96

**H2006B-3** <---> 32 1.79 2.16 2.53 2.90

**H2007B-3** <---> 32 2.15 2.60 3.04 3.49

**H2008B-3** <---> 32 3.23 3.90 4.56 5.23

**H2009B-3** <---> 32 4.55 5.50 6.45 7.40

**H2010B-3** <---> 32 6.75 8.17 9.58 11.0

**H2011B-3** <---> 32 9.14 10.8 12.4 14.0

**H2012B-3** <---> 32 14.0 16.9 19.9 22.8

**H2013B-3** <---> 32 18.7 22.7 26.7 30.7

**H2014B-3** <---> 32 23.5 28.5 33.5 38.5



# Practical overload selection

Heater Element Selection Procedure — When Temperature at Controller is  $\pm 10^{\circ}\text{C}$  ( $\pm 18^{\circ}\text{F}$ ) Greater than Temperature at Motor

The ambient temperature at the motor and controller is the same in most applications. Under this condition, the overload relay is designed to sense changes in ambient temperature and also protect the motor over a range of temperatures.

# Ambient Temperature Correction



Output that a motor can safely deliver varies with temperature. The motor can deliver its full rated horsepower at an ambient temperature specified by the motor manufacturers, normally  $+40^{\circ}\text{C}$  ( $+104^{\circ}\text{F}$ ).

At high temperatures (higher than  $+40^{\circ}\text{C}$ ) less than 100% of the normal rated current can be drawn from the motor without shortening the insulation life.

At lower temperatures (less than  $+40^{\circ}\text{C}$ ) more than 100% of the normal rated current could be drawn from the motor without shortening the insulation life

Thus, there is an inverse relationship between motor ambient temperature and motor output. In any motor, allowable output decreases as the ambient temperature is raised and vice versa.

# Overload selection

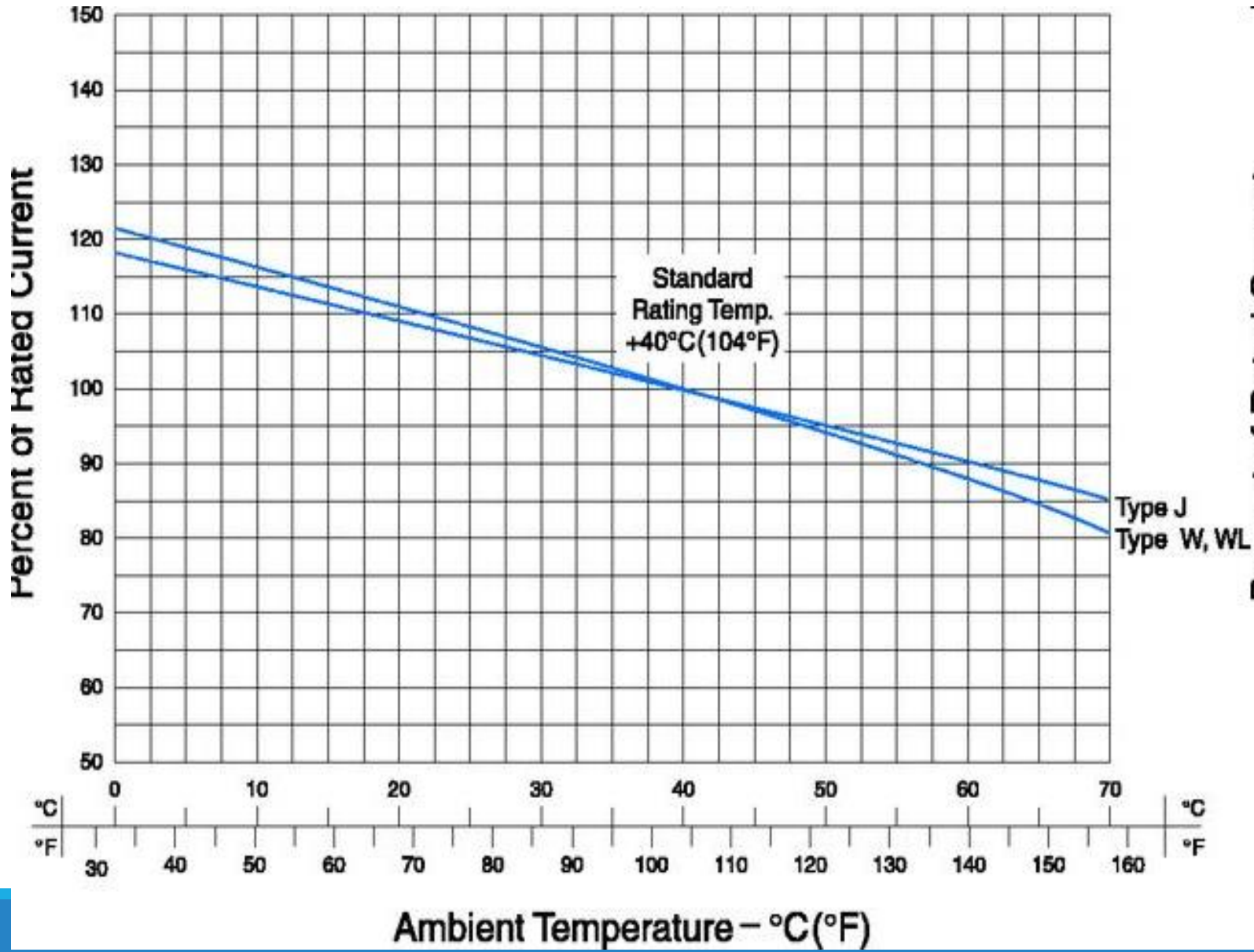



# Heater Element Tables

The heater element selection tables are designed to accommodate motor service factors of 1.15 or greater, as given in all the preceding examples. If the service factor had been less than 1.15 (for example, S.F. = 1.0) a heater element one rating smaller than selected in each example would have been the correct choice. This would provide protection at 10% lower current levels.

# Heater Table Instructions



1. Determine number of heater elements required from Table A.
2. Determine motor full load current and service factor.

NOTE: If motor amps are unknown, an approximate value may be found. These values should be used with caution and only when motor amps are not available.

3. If the motor and controller are in the same ambient temperature:
  - a. For 1.15 to 1.25 service factor motors use 100% of motor full load current for heater element selection.
  - b. For 1.0 service factor motors use 90% of motor full load current for heater element selection.
  - c. Heater elements are class 20.
4. If the motor and controller are in different ambient temperatures multiply motor full load current by the multiplier. Use the resultant full load current for heater element selection.
5. Select proper heater element from table below.
6. All tables are based on the operation of the motor and controller in the same ambient temperature, 40°C (104°F) or less. Always be certain the correct heater element is installed in the starter before operating the motor.

# Electronic overload selection

Electronic Overload Relay.

Selectable trip class.

Selectable reset mode.

Overload setting is 120% of motor current.

For 1.15 Service Factor or greater, set at motor nameplate current. SF less than 1.15, set at 90% of motor current.

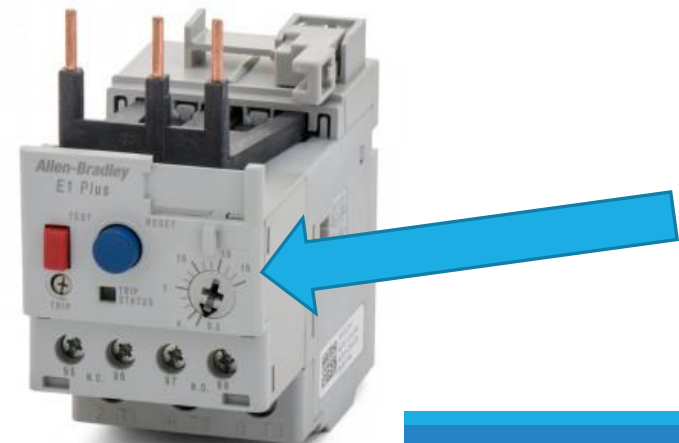

Allen-Bradley  
E1 Plus

TEST

RESET

Test Button



Reset Button

Trip Setting

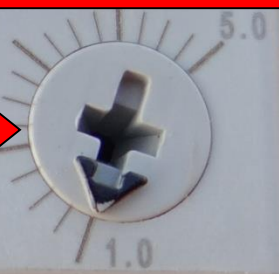

TRIP

STATUS

NC Contact



95 N.C.



96



97

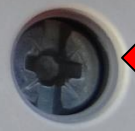

N.O. 98

NO Contact



2 T1



4 T2



6 T3

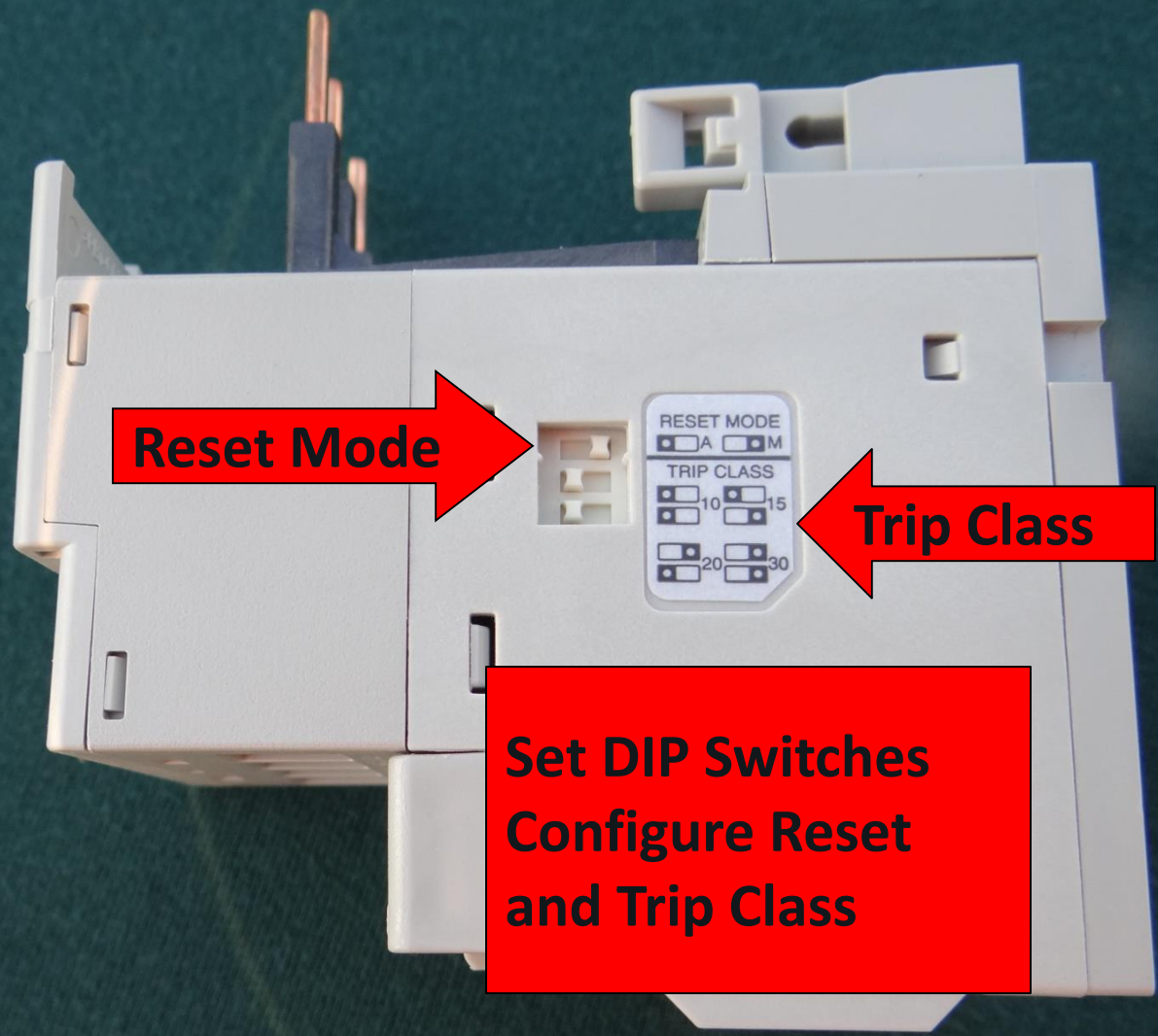

**Reset Mode**

**Trip Class**

**Set DIP Switches  
Configure Reset  
and Trip Class**



# Worksheet Example OL setting

## Motor Branch Circuit Calculations

HP	Motor	Volts	PH	Name-plate Current Rating	Code Letter	Service Factor	Maximum Locked-Rotor Current	Minimum Size THWN Conductor	Maximum trip current of OL Breaker	Maximum SC & GF Dual-Element Time-Delay Fuse	Minimum Controller Size
75	M-1	460	3	92	H	1.15	667	1 AWG			
60	M-2	460	3	68	G	1.15	474	3 AWG			
50	M-3	460	3	58	G	1.15	395	4 AWG			
40	M-4	460	3	46	H	1.00	356	6 AWG			

## Motor Feeder Calculations

Minimum Circuit Ampacity	Minimum Size THWN Conductor	Maximum SC & GF Dual-Element, Time-Delay, Fuse
314	400 kcmil	



# Worksheet Answers

## Motor Branch Circuit Calculations

HP	MOTOR	VOLTS	PH	Name Plate Current Rating	Code Book Current Value	Code Letter	Service Factor	Maximum Locked Rotor Current	Minimum Size THWN Conductor	Maximum Trip Setting	Maximum SC & GF Dual-Element Time-Delay Fuse	Minimum Controller Size
75	M-1	460	3	92	96	H	1.15	667	1 AWG	115		
60	M-2	460	3	68	77	G	1.15	474	3 AWG	85		
50	M-3	460	3	58	65	G	1.15	395	4 AWG	72.5		
40	M-4	460	3	46	52	H	1.00	356	6 AWG	52.9		

## Motor Feeder Calculations

Minimum Circuit Ampacity	Minimum Size THWN Conductor	Maximum SC & GF Dual Element, Time Delay Fuse
314	400 kcmil Cu	



# Formulas — Approximate Full Load Amps for Other Motors

---

208 Volt Full Load Amp = 230 Volt current  $\times$  110%

Service factor 1.0 = amps  $\times$  0.9

50°C–55°C motor = amps  $\times$  0.9

# 430.36/37/38 – Overload Installation Guidelines



## 430.36 Fuses — In Which Conductor.

Where **fuses are used for motor overload protection, a fuse shall be inserted in each ungrounded conductor** and also in the grounded conductor if the supply system is 3-wire, 3-phase ac with one conductor grounded. (corner grounded Delta)



# 430.37 Devices Other Than Fuses — In Which Conductor

Where devices other than fuses are used for **motor overload protection**, **Table 430.37 shall govern the minimum allowable number and location of overload units** such as trip coils or relays.



**Table 430.37 Overload Units**

Kind of Motor	Supply System	Number and Location of Overload Units, Such as Trip Coils or Relays
1-phase ac or dc	2-wire, 1-phase ac or dc ungrounded	1 in either conductor
1-phase ac or dc	2-wire, 1-phase ac or dc, one conductor grounded	1 in ungrounded conductor
1-phase ac or dc	3-wire, 1-phase ac or dc, grounded neutral conductor	1 in either ungrounded conductor
1-phase ac	Any 3-phase	1 in ungrounded conductor
2-phase ac	3-wire, 2-phase ac, ungrounded	2, one in each phase
2-phase ac	3-wire, 2-phase ac, one conductor grounded	2 in ungrounded conductors
2-phase ac	4-wire, 2-phase ac, grounded or ungrounded	2, one for each phase in ungrounded conductors
2-phase ac	Grounded neutral or 5-wire, 2-phase ac, ungrounded	2, one for each phase in any ungrounded phase wire
3-phase ac	Any 3-phase	3, one in each phase*

*\*Exception: An overload unit in each phase shall not be required where overload protection is provided by other approved means.*

# 430.37 Devices Other Than Fuses in Which Conductor.

# 430.38 Number of Conductors Opened by Overload Device



Motor overload devices, other than fuses or thermal protectors, shall simultaneously open a sufficient number of ungrounded conductors to interrupt current flow to the motor.

## Part IV



---

# Sizing Motor Short Circuit and Ground Fault Protection

# Definition: Short-Circuit

---



An unintentional, electrically conductive connection of low impedance between conductors of an electrical circuit, or circuit conductors of equipment.

A short-circuit is one of three possible overcurrent conditions.



# Definition: Ground-Fault (NEC)

An unintentional, electrically conductive connection between an ungrounded conductor of an electrical circuit and the normally non-current-carrying conductors, metallic enclosures, metallic raceways, metallic equipment, or earth.

A ground-fault is one of three possible overcurrent conditions.



# 430.51/52 – Sizing the Overcurrent Protection

---

## (C) Rating or Setting.

- (1) In Accordance with Table 430.52. A protective device that has a **rating or setting not exceeding the value calculated according to the values given in Table 430.52** shall be used.

# Table 430.52

Type of Motor	Percentage of Full-Load Current				
	Fuse	Nontime Delay Fuse	Dual Element Time-Delay	Instant Trip Breaker	Inverse Time Breaker
Single-phase motors		300	175	800	250
AC polyphase motors other than wound-rotor		300	175	800	250
Squirrel cage — other than Design B energy-efficient		300	175	800	250
Design B energy-efficient:		300	175	1100	250
Synchronous <sup>3</sup>		300	175	800	250
Wound rotor		150	150	800	150
Direct current		150	150	250	150

# Notes to Table 430.52



Note: For certain exceptions to the values specified, see 430.54.

---

1. The values in the **Nontime Delay Fuse** column applies to **Time-Delay Class CC fuses**.
2. The values given in the **last column** also covers the ratings of **nonadjustable inverse time types of circuit breakers** that may be modified as in 430.52(C)(1), Exception No. 1 and No. 2.
3. **Synchronous motors of the low-torque, low-speed type** (usually 450 rpm or lower), such as are used to drive reciprocating compressors, pumps, and so forth, that start unloaded, do not require a fuse rating or circuit-breaker setting in excess of **200 percent** of full-load current.



# 430.52 – Sizing Overcurrent Protection Sample Motor

---

$$40 \times 1.75 = 70 \text{ amps}$$

70-amp **Dual Element Fuse**

Exception 1 would allow going to the next standard OCP device if the calculation does not match a standard size



# Worksheet Short Circuit Protection

## Motor Branch Circuit Calculations

HP	Motor	Volts	PH	Name-plate Current Rating	Code Letter	Service Factor	Maximum Locked-Rotor Current	Minimum Size THWN Conductor	AB 193-E1 Plus Overload Maximum Dial Setting	Maximum SC & GF Dual-Element Time-Delay Fuse	Minimum Controller Size
75	M-1	460	3	92	H	1.15	667	1 AWG	92		
60	M-2	460	3	68	G	1.15	474	3 AWG	68		
50	M-3	460	3	58	G	1.15	395	4 AWG	58		
40	M-4	460	3	46	H	1.00	356	6 AWG	41.4		

## Motor Feeder Calculations

Minimum Circuit Ampacity	Minimum Size THWN Conductor	Maximum SC & GF Dual-Element, Time-Delay, Fuse
314	400 kcmil	

# Worksheet **Answers**



## Motor Branch Circuit Calculations

HP	Motor	Volts	PH	Name-plate Current Rating	Code Letter	Service Factor	Maximum Locked-Rotor Current	Minimum Size THWN Conductor	AB 193-E1 Plus Overload Maximum Dial Setting	Maximum SC & GF Dual-Element Time-Delay Fuse	Minimum Controller Size
75	M-1	460	3	92	H	1.15	667	1 AWG	92	175	
60	M-2	460	3	68	G	1.15	474	3 AWG	68	150	
50	M-3	460	3	58	G	1.15	395	4 AWG	58	125	
40	M-4	460	3	46	H	1.00	356	6 AWG	41.4	100	

## Motor Feeder Calculations

Minimum Circuit Ampacity	Minimum Size THWN Conductor	Maximum SC & GF Dual-Element, Time-Delay, Fuse
314	400 kcmil	

# Fusetron® Dual-Element, Time-Delay, Class RK5 Fuses



**FRN-R (250V)**

**Dual-Element, Time-Delay – 10 seconds (minimum) at 500% rated current**

**Ampere Ratings: 1/10 - 600 amps**

**Voltage Rating: 250 Volts AC (or less), 125 Volts DC**

**Current Limiting RK5 Fuse**

**Interrupting Rating: 200,000A RMS Sym. (20,000A @ 125V DC)**





# 430.52 – Sizing Overcurrent Protection

---

## Sample Motor

- An RK5 Fuse will handle **500% for 10 seconds**
- $70 \text{ amp} \times 5 = 350 \text{ amps}$ .
- A 70 amp RK5 fuse will carry 350 amps for 10 seconds.
- Inrush current for this motor is 144 amps

**OK to use for sample motor?**

# V. Motor Feeder Short-Circuit and Ground Fault Protection



## 430.62 Rating or Setting — Motor Load.

---

(A) Specific Load. A feeder supplying a specific fixed motor load(s) and consisting of conductor sizes based on 430.24 shall be provided with a protective device having a rating or setting not greater than the largest rating or setting of the branch-circuit short-circuit and ground-fault protective device for any motor supplied by the feeder [based on the maximum permitted value for the specific type of a protective device in accordance with 430.52, or 440.22(A) for hermetic refrigerant motor-compressors], plus the sum of the full-load currents of the other motors of the group.

# V. Motor Feeder Short-Circuit and Ground-Fault Protection

---



## (B) Other Installations.

Where feeder conductors have an ampacity greater than required by 430.24, the rating or setting of the feeder overcurrent protective device shall be permitted to be based on the ampacity of the feeder conductors.

# 430.63 Rating or Setting — Power and Lighting Loads



---

Where a feeder supplies a motor load and, in addition, a lighting, or a lighting and appliance load, the feeder protective device shall have a rating sufficient to carry the lighting or lighting and appliance load, plus the following:

- (1) For a single motor, the rating permitted by 430.52
- (2) For a single hermetic refrigerant motor-compressor, the rating permitted by 440.22
- (3) For two or more motors, the rating permitted by 430.62

*Exception: Where the feeder overcurrent device provides the overcurrent protection for a motor control center, the provisions of 430.94 shall apply.*

# Calculate the feeder conductor and overcurrent protection

---



7.5 HP, 230 V, 20A, three phase, SF 1.0, Cont. Duty, Design B, Code R, 1725 RPM, 60Hz,

30 HP, 230 V, 78A, SF.1.15, Cont. Duty, Design B, Code D, 1150 RPM, 60HZ



# Calculate the feeder conductor and overcurrent protection

---

Table 430.250 Values for:            7.5 HP = 22A

30 HP = 80A

$$80 \times 1.25 = 100 \text{ amps} + 22 = 122 \text{ A}$$

122 amps = 1 AWG Feeder Conductor

# Calculate the feeder conductor and overcurrent protection



---

Table 430.250 Values for: 7.5 HP = 22 A

30

HP = 80 A

$80 \times 1.75 = 140 \text{ amp}$

430.52 E  $\times$  1 allows to go up to the next standard size = 150 amps

150 amps + 22 = 172 amps = 150 Amp OCP





# Worksheet Feeder Protection

## Motor Branch Circuit Calculations

HP	Motor	Volts	PH	Name-plate Current Rating	Code Letter	Service Factor	Maximum Locked-Rotor Current	Minimum Size THWN Conductor	AB 193-E1 Plus Overload Maximum Dial Setting	Maximum SC & GF Dual-Element Time-Delay Fuse	Minimum Controller Size
75	M-1	460	3	92	H	1.15	667	1 AWG	92	175	
60	M-2	460	3	68	G	1.15	474	3 AWG	68	150	
50	M-3	460	3	58	G	1.15	395	4 AWG	58	125	
40	M-4	460	3	46	H	1.00	356	6 AWG	41.4	100	

## Motor Feeder Calculations

Minimum Circuit Ampacity	Minimum Size THWN Conductor	Maximum SC & GF Dual-Element, Time-Delay, Fuse
314	400 kcmil	



# Worksheet Answers

## Motor Branch Circuit Calculations

HP	Motor	Volts	PH	Name-plate Current Rating	Code Letter	Service Factor	Maximum Locked-Rotor Current	Minimum Size THWN Conductor	AB 193-E1 Plus Overload Maximum Dial Setting	Maximum SC & GF Dual-Element Time-Delay Fuse	Minimum Controller Size
75	M-1	460	3	92	H	1.15	667	1 AWG	92	175	
60	M-2	460	3	68	G	1.15	474	3 AWG	68	150	
50	M-3	460	3	58	G	1.15	395	4 AWG	58	125	
40	M-4	460	3	46	H	1.00	356	6 AWG	41.4	100	

## Motor Feeder Calculations

Minimum Circuit Ampacity	Minimum Size THWN Conductor	Maximum SC & GF Dual-Element, Time-Delay, Fuse
314	400 kcmil	350



# END PART 1

(2 of 4 hours)

---